



**Lynn Lake Gold Project:  
Erosion and Sediment  
Control Plan**

Version 0

January 30, 2025

**LYNN LAKE GOLD PROJECT:  
EROSION AND SEDIMENT CONTROL PLAN**

## Document History

### Document Location

This is an on-line document. Paper copies are valid only on the day they are printed. Refer to the author or the Controlled Document Directory on the Alamos public drive to ensure the latest version.

### Revision History

Effective Date:	Date of Last Revision:
-----------------	------------------------

Revision #	Date	Summary of Changes	Author

### Approvals

This document requires the following approvals:

Name	Company Title	Date	Signature

## **Table of Contents**

<b>ACRONYMS AND ABBREVIATIONS .....</b>	<b>III</b>
<b>GLOSSARY .....</b>	<b>IV</b>
<b>1.0 INTRODUCTION.....</b>	<b>1</b>
1.1 PURPOSE.....	1
1.2 OBJECTIVE .....	1
1.3 RELATIONSHIP TO OTHER MANAGEMENT PLANS.....	1
1.4 REGULATORY CONTEXT .....	2
1.4.1 Federal Regulatory Requirements.....	2
1.4.2 Provincial Regulatory Requirements .....	3
1.4.3 Corporate or Other Policies .....	3
1.4.4 Approval Related Requirements.....	7
<b>2.0 ENVIRONMENTAL SETTING .....</b>	<b>10</b>
2.1 POTENTIAL PROJECT EFFECTS .....	10
<b>3.0 MITIGATION AND MANAGEMENT MEASURES.....</b>	<b>12</b>
3.1 CONSTRUCTION .....	12
3.2 OPERATION .....	15
3.3 DECOMMISSIONING/CLOSURE/POST CLOSURE.....	16
3.4 BEST MANAGEMENT PRACTICES.....	17
<b>4.0 MONITORING.....</b>	<b>20</b>
4.1 CONSTRUCTION .....	20
4.1.1 Monitoring of Vegetation Clearing and Sensitive Area Demarcation.....	20
4.1.2 Monitoring of Work Areas .....	21
4.1.3 Monitoring of Ditches, Stockpiles, Dewatering Activities, and other Earthworks.....	21
4.1.4 Water Quality Monitoring for Total Suspended Solids.....	22
4.2 OPERATION .....	22
4.2.1 Monitoring of Ditches, Stockpiles, and other Earthworks .....	22
4.2.2 Water Quality Monitoring for Total Suspended Solids.....	22
4.3 DECOMMISSIONING/CLOSURE/POST CLOSURE.....	22
4.3.1 Monitoring of Work Areas .....	22
4.3.2 Monitoring of Ditches, Stockpiles, and other Earthworks .....	22
4.3.3 Water Quality Monitoring for Total Suspended Solids.....	22
<b>5.0 ADAPTIVE MANAGEMENT .....</b>	<b>23</b>
5.1 THRESHOLDS FOR ADAPTIVE MANAGEMENT.....	23
<b>6.0 REPORTING.....</b>	<b>30</b>
<b>7.0 REFERENCES.....</b>	<b>31</b>

**LYNN LAKE GOLD PROJECT:  
EROSION AND SEDIMENT CONTROL PLAN**

**LIST OF TABLES**

Table 1-1	Corporate Sustainability Standards .....	4
Table 1-2	Approval Related Requirements .....	8
Table 3-1	Mitigation Measures for Erosion and Sediment Control during Construction .....	12
Table 3-2	Mitigation Measures for Erosion and Sediment Control during Operation .....	15
Table 3-3	Mitigation Measures for Erosion and Sediment Control during Decommissioning/Closure/Post Closure .....	16
Table 3-4	Best Management Practices for Erosion and Sediment Control .....	17
Table 4-1	Summary of Monitoring Activities for the Erosion and Sediment Control Plan .....	21

**LIST OF APPENDICES**

- Appendix A Best Management Practices
- Appendix B Maps

# LYNN LAKE GOLD PROJECT: EROSION AND SEDIMENT CONTROL PLAN

Introduction  
January 30, 2025

## Acronyms and Abbreviations

Alamos	Alamos Gold Inc.
BMP	Best Management Practices
CCME	Canadian Council of Ministers of the Environment
CEAA 2012	<i>Canadian Environmental Assessment Act, 2012</i>
EIS	Environmental Impact Statement
ESCP	Erosion and Sediment Control Plan
HSE	Health, Safety, and Environment
MECC	Manitoba Environment and Climate Change (formerly Manitoba Environment, Climate and Parks, and formerly Manitoba Conservation and Climate)
the Project	Lynn Lake Gold Project
QA/QC	Quality Assurance/Quality Control
RGMP	Responsible Gold Mining Principles
TMF	Tailings Management Facility
TSS	Total Suspended Solids

**LYNN LAKE GOLD PROJECT:  
EROSION AND SEDIMENT CONTROL PLAN**

Introduction  
January 30, 2025

## **Glossary**

Adaptive Management	The process of using the findings from ongoing monitoring to continually improve mitigation strategies and procedures to further lessen effects on selected valued component.
Contact Water	Surface water or groundwater that has contacted mine workings or interacted with mine rock
Deleterious substance	Any substance that, if added to any water, would degrade or alter, or form part of a process of degradation or alteration of the quality of that water so that it is rendered or is likely to be rendered deleterious to fish or fish habitat or to the use by man of fish that frequent that water, or if by going through some process of degradation, it harms the water quality ( <i>Fisheries Act</i> (paragraph 34(1)(a))). A substance is also deleterious if it exceeds a level prescribed by regulation.
Mitigation	A planned activity or process that reduces the severity of a potential effect on a selected valued component.
Monitoring	A planned activity used to evaluate the progress or effectiveness of mitigation measures and verify environmental assessment predictions.
Non-contact water	Surface water or groundwater that has not contacted mine workings or interacted with mine rock.
Project Development Area	The immediate area in which Project activities and components may occur plus a 30-metre (m) buffer.
Total suspended solids	Quantitative water quality measurement of the suspended solids, or sediment, in the water column and is the direct measurement of the total solids present in a waterbody.
Turbidity	Measure of the lack of clarity or transparency of water caused by biotic and abiotic suspended or dissolved substances. The higher the concentration of these substances in water, the more turbid the water becomes

# LYNN LAKE GOLD PROJECT: EROSION AND SEDIMENT CONTROL PLAN

Introduction  
January 30, 2025

## 1.0 INTRODUCTION

The following presents the Erosion and Sediment Control Plan ('ESCP' or 'the Plan'), which considers the construction, operation, and decommissioning/closure phases of the Lynn Lake Gold Project ('LLGP' or 'the Project') and the mitigation, management, and monitoring of Project-related effects causing erosion or sedimentation. The ESCP is a component of the overall Environmental Management and Monitoring Program ('EMMP') for the Project.

### 1.1 PURPOSE

The purpose of the ESCP is to recommend measures to protect terrestrial and aquatic environments and to protect watercourses and wetlands from sedimentation during construction, operation, and decommissioning/closure. The ESCP has been prepared in accordance with provincial and federal legislation and guidelines, as well as applicable site-specific policies and procedures.

Mitigation measures to avoid or reduce effects associated with erosion and sedimentation will be implemented throughout the life of the Project (see Section 3.0 and Appendix A). Monitoring (follow-up) will occur during all Project phases, and adaptive management will be implemented as needed.

### 1.2 OBJECTIVE

Adherence to the ESCP will provide results which are measurable (where possible) and reportable.

The objectives of the ESCP are to:

- Establish guidelines and procedures for the construction, operation, and decommissioning/closure phases of the Project to reduce the potential for erosion and sedimentation.
- Describe erosion and sediment control measures to reduce adverse, sediment-related effects to potential receiving waterbodies.
- Outline monitoring activities that will be used to assess the effectiveness of erosion and sediment control measures and apply adaptive management to the Project as needed.

### 1.3 RELATIONSHIP TO OTHER MANAGEMENT PLANS

Relevant plans that contribute directly or indirectly to the mitigation, management, and/or monitoring of erosion and sediment control, include the following:

- Acid Rock Drainage and Metal Leaching Management and Monitoring Plan
- Air Quality Management and Monitoring Plan (AQMMP)
- Aquatic Effects Monitoring Program (AEMP)

# LYNN LAKE GOLD PROJECT: EROSION AND SEDIMENT CONTROL PLAN

Introduction  
January 30, 2025

- Emergency Response and Spill Prevention and Contingency Plan
- Environmental Effects Monitoring Plan
- Fish Habitat Offsetting Plan
- Soil Management and Rehabilitation Plan
- Surface Water Management and Monitoring Plan (SWMMP)
- Vegetation and Weed Management Plan.

## 1.4 REGULATORY CONTEXT

The Project Environmental Impact Statement (EIS) was submitted to the Impact Assessment Agency of Canada (formerly the Canadian Environmental Assessment Agency) pursuant to the *Canadian Environmental Assessment Act* (CEAA) 2012, and to Manitoba Environment and Climate Change (MECC; formerly Manitoba Environment, Climate and Parks and formerly Manitoba Conservation and Climate) as an Environment Act Proposal pursuant to *The Environment Act* of Manitoba. The relevant federal and provincial regulatory requirements related to erosion and sediment control for the Project are outlined below.

### 1.4.1 Federal Regulatory Requirements

#### *Fisheries Act*

The *Fisheries Act* and associated Metal and Diamond Mining Effluent Regulations (MDMER) administered by Environment and Climate Change Canada (ECCC) and Fisheries and Oceans Canada (DFO), are the primary instruments guiding the application of erosion and sediment control measures for the Project. Under the MDMER, total suspended solids (i.e., sedimentation) may be considered a deleterious substance, in violation of Section 36(3) of the *Fisheries Act*. The Canadian Council of Ministers of the Environment (CCME) also provide guidelines for particulate matter in freshwater environments via the Canadian Water Quality Guidelines for Protection of Aquatic Life – Total Particulate Matter (CCME 2002).

#### Canadian Navigable Waters Act

The *Canadian Navigable Waters Act* administered by Transport Canada is the primary instrument guiding the protection of the public's right to navigation on navigable waters. Under Section 21 and 22(1) of the Act, it is prohibited to throw or deposit materials into waters that are navigable or flow into any navigable water.

## LYNN LAKE GOLD PROJECT: EROSION AND SEDIMENT CONTROL PLAN

Introduction  
January 30, 2025

### 1.4.2 Provincial Regulatory Requirements

#### *The Water Protection Act*

*The Water Protection Act*, administered by Manitoba Conservation and Climate, provides for the protection of freshwater biota and human and wildlife consumers of fish. The Manitoba Water Quality Standards, Objectives, and Guidelines Regulation establishes water quality guidelines for the protection of aquatic life (MWS 2011).

#### *The Mines and Minerals Act*

*The Mines and Minerals Act*, administered by Manitoba Agriculture and Resource Development, guides how water that is removed from a mine lease must be disposed of safely and securely. The Mine Closure Regulation of the Act stipulates requirements for restoration of watercourses during mine closure.

### 1.4.3 Corporate or Other Policies

As a member of the World Gold Council, Alamos Gold Inc. (Alamos) is a proud supporter of the Responsible Gold Mining Principles (the RGMPs). The ten RGMPs provide a framework that sets expectations for consumers, investors, and the downstream gold supply chain as to what constitutes responsible gold mining, addressing key environmental, social and governance issues for the gold mining sector. They are designed to provide confidence to governments, investors, employees and contractors, communities, supply chain partners and civil society that gold has been produced responsibly. Following the release of the RGMPs in September 2019, Alamos has implemented and aligned to the framework, and obtained external assurance to provide further confidence that the gold produced by Alamos is responsibly mined. In 2023, Alamos communicated its progress on implementing the RGMPs through Alamos' 2022 RGMP Progress Report which received independent audit/assurance from EEM EHS Management Inc. (Alamos 2023). The 2022 RGMP Progress Report reflects Alamos' third year reporting under the RGMP. Alamos will continue to implement the RGMPs through 2024 and beyond. The RGMPs are only applicable to operating mines. The Lynn Lake Gold Project will be incorporated as it transitions through construction into operation.

Working with its members, the World Gold Council has set out RGMPs to address key environmental, social and governance issues for the gold mining sector. One of the key principles is Water, Energy and Climate Change.

Alamos also has a Sustainability Policy. For Alamos, sustainability encompasses excellence in health and safety, environmental management, community engagement, security and human rights. The Policy outlines Alamos' commitment to build, operate and close mines in a manner that supports our sustainability vision and promotes the Alamos core values of Safety, Teamwork, Environmental Sustainability, Integrity and Commitment. The Policy is a key element of the Alamos Sustainability Framework and is supported by Corporate Sustainability Standards that guide site procedures and practices.

**LYNN LAKE GOLD PROJECT:  
EROSION AND SEDIMENT CONTROL PLAN**

Introduction  
January 30, 2025

Alamos has a series of guiding corporate sustainability standards (Table 1-1), including:

- Environmental Monitoring
- Hazard Identification & Risk Management
- Incident Classification, Investigation & Reporting.

Those corporate Standards that may be applicable specifically to the Erosion and Sediment Control Plan include:

- Water Management
- Biodiversity & Land Use Management
- Mine Closure.

Alamos' standards are regularly updated to reflect the latest developments. For the most current and up-to-date standards, please refer to the online (internal) version.

**Table 1-1 Corporate Sustainability Standards**

<b>Corporate Standard</b>	<b>Requirement</b>
Environmental Monitoring (CSS-ENV-10.1)	Sites shall develop and implement an environmental monitoring program. The site's environmental monitoring program will be documented as to: list of points monitored, coordinates of points monitored, description of points (including the reason for monitoring (e.g., regulatory compliance, baseline, trend analysis, etc.), frequency of monitoring, anticipated duration of monitoring (e.g., the life of the mine), and parameters monitored. The monitoring program will be of sufficient scope to allow for the timely identification of potential environmental impacts prior to their migration offsite. Sites will regularly review their monitoring programs and update for and changes at the mine site as required. At a minimum the program will meet all environmental regulatory requirements.
Environmental Monitoring (CSS-ENV-10.2)	Compliance monitoring data will be subject to Quality Assurance/Quality Control (QA/QC) verification. Sample results that do not meet QA/QC guidelines will be disregarded and sample collection repeated. Sites must use reliable and accredited labs.
Environmental Monitoring (CSS-ENV-10.3)	Monitoring data will be stored in an electronic database.
Environmental Monitoring (CSS-ENV-10.4)	When compliance monitoring results indicate exceedances from permit or regulatory requirements, or significant deviation from previous results, the results will be reconfirmed with the person or company that did the analysis, and a confirmatory monitoring or sample will be taken immediately if the result is reconfirmed. Sites will also follow any permit-specific or jurisdictional requirements.
Environmental Monitoring (CSS-ENV-10.5)	Monitoring data will be reviewed at least quarterly by the responsible manager to identify trends that may indicate potential for future exceedances from permit conditions or applicable standards, and potential risk. The site General Manager will be formally notified of any exceedances and emerging compliance issues. Refer to CSS-GOV-08 Incident Reporting Standard for any moderate, major or catastrophic incidents.

**LYNN LAKE GOLD PROJECT:  
EROSION AND SEDIMENT CONTROL PLAN**

Introduction  
January 30, 2025

<b>Corporate Standard</b>	<b>Requirement</b>
Environmental Monitoring (CSS-ENV-10.6)	Sites will assess the need for a monitoring program involving external stakeholders.
Hazard Identification & Risk Management (CSS-GOV-2.1)	All Alamos locations shall maintain systems to identify, prevent and/or manage sustainability risks that face its operations and those which its activities may pose to others. This includes but is not limited to hazards and risks related to the: <ul style="list-style-type: none"> <li>• Health and Safety of our workforce and communities,</li> <li>• Environmental impacts of our activities (local and downstream),</li> <li>• Societal and community impacts, and</li> <li>• Security and protection of people and property.</li> </ul>
Hazard Identification & Risk Management (CSS-GOV-2.2)	Site Managers are responsible to ensure that appropriate resources, both internal and external, are available to identify, quantify, manage and report sustainability hazards and risks. Assessments shall consider all site activities including: <ul style="list-style-type: none"> <li>• Contractor works,</li> <li>• Regulatory requirements</li> <li>• Permit or licence requirements,</li> <li>• Alamos Sustainability Standards requirements, and</li> <li>• Other site-specific requirements.</li> </ul>
Hazard Identification & Risk Management (CSS-GOV-2.3)	Sites shall maintain a risk registry of all site risks. The risk registry will be updated at least quarterly or when major changes/incidents occur. Clear responsibility and authority for implementing, managing, reporting and coordinating updates to the risk registry shall be designated to a specific employee(s).
Hazard Identification & Risk Management (CSS-GOV-2.4)	All corporate, site and task-level risks shall be assessed against the Alamos Risk Matrix, including likelihood and consequence assessments.
Hazard Identification & Risk Management (CSS-GOV-2.5)	Sites shall apply the hierarchy of controls considering (in order of priority): <ol style="list-style-type: none"> <li>1. Elimination – Remove the hazard</li> <li>2. Substitution – Replace the hazard</li> <li>3. Engineering control – physically control or isolate the hazard (e.g., dikes, guarding, interlocks)</li> <li>4. Administrative control – control response/avoidance of hazard (e.g., training, procedures, reducing employee exposure to hazards, signage)</li> <li>5. PPE or Mitigation – Protect people (personal protective equipment) or the environment (spill kits) from the hazard. This is the last line of defense.</li> </ol> Extreme and high risks that exist after controls have been applied should go through a formal review with the Site Manager.
Hazard Identification & Risk Management (CSS-GOV-2.6)	Sites shall ensure effective communication of risks and controls to the workforce based on the nature of the activity and related risk. The nature of communication may change based on the risk frequency and consequence. For example, communication may include induction training, refresher training, policies, procedures and/or signage.

**LYNN LAKE GOLD PROJECT:  
EROSION AND SEDIMENT CONTROL PLAN**

Introduction  
January 30, 2025

<b>Corporate Standard</b>	<b>Requirement</b>
Hazard Identification & Risk Management (CSS-GOV-2.7)	For each identified risk, management shall assess and manage the risk appropriately with consideration to the risk rating. In considering risk mitigation, management must evaluate the cost of controls versus the benefit derived and ensure the resultant control framework is effective.
Hazard Identification & Risk Management (CSS-GOV-2.9)	The Alamos Executive and Internal Audit Director shall review and verify enterprise risks on a quarterly basis.
Incident Classification, Investigation & Reporting (CSS-GOV-8.3)	The Corporate Sustainability Team shall maintain an Incident Alert email group user list comprised of, at a minimum: <ul style="list-style-type: none"> <li>• Alamos Executive and Management,</li> <li>• Country Managers,</li> <li>• General Managers; and</li> <li>• Project Managers.</li> </ul>
Incident Classification, Investigation & Reporting (CSS-GOV-8.6)	The Corporate Sustainability Team shall provide a report on significant incidents on a quarterly basis to senior management and the Technical & Sustainability Committee of the Board.
Incident Classification, Investigation & Reporting (CSS-GOV-8.7)	Corporate Sustainability and Risk Management teams shall annually review and revise the Alamos Risk Assessment Consequence Table to ensure thresholds are consistent with the Alamos Enterprise Risk Management system.
Biodiversity & Land Use (CSS-ENV-7.1)	Prior to any new surface disturbance, notification must be given to the Environmental departments to obtain authorization, and any required jurisdictional or land access permits secured, before any work is started.
Biodiversity & Land Use (CSS-ENV-7.2)	Prior to any surface disturbance, sites will evaluate risks of potential impacts to sensitive resources, including: <ul style="list-style-type: none"> <li>• Cultural resources</li> <li>• Traditional knowledge or historical community use</li> <li>• Territorial lands</li> <li>• Historical or archeological features</li> <li>• Threatened or endangered wildlife and vegetation species</li> <li>• Sensitive areas</li> <li>• Sensitive habitats</li> <li>• Wetlands</li> </ul> <p>If risks are identified, a Biodiversity and Land Use Management Plan will be developed, implemented and maintained in order to avoid, minimize, mitigate, or offset disturbance.</p>
Biodiversity & Land Use (CSS-ENV-7.3)	Sensitive resources discovered during site activities will be reported to site management and the proper authorities. Impacts to these sensitive resources and any unauthorized collection is prohibited during project construction, operations and closure.
Biodiversity & Land Use (CSS-ENV-7.5)	Sites will minimize ecosystem disturbance to only what is essential for safe efficient operation (including vegetation clearance, soil disturbance, noise, vibration and artificial lighting).
Biodiversity & Land Use (CSS-ENV-7.7)	Sites will manage any buffer zones or other areas not required for mining and associated activity so as to minimize disturbance and conserve or increase biodiversity.

**LYNN LAKE GOLD PROJECT:  
EROSION AND SEDIMENT CONTROL PLAN**

Introduction  
January 30, 2025

<b>Corporate Standard</b>	<b>Requirement</b>
Biodiversity & Land Use (CSS-ENV-7.8)	When required by regulation, permit, external commitments, or when potentially significant biodiversity and land use risks and obligations are identified, sites will develop, formalize and implement a Biodiversity and Land Use Management Plan.
Mine Closure (CSS-ENV-9.5)	Physical restoration and stability shall be described in the LOM closure plan and integrated into the mine plan, including: <ul style="list-style-type: none"><li>• Water management including seepage collection, diversion of non-contact water, and drainage and erosion control for storm events and groundwater inputs.</li></ul>

**1.4.4 Approval Related Requirements**

The conditions relating to erosion and sediment control laid out in the federal Decision Statement issued under CEAA, 2012, provincial Environmental Act Licence No. 3390 (Gordon), and provincial Environmental Act Licence No. 3391 (MacLellan) are outlined in Table 1-2.

**LYNN LAKE GOLD PROJECT:  
EROSION AND SEDIMENT CONTROL PLAN**

Introduction  
January 30, 2025

**Table 1-2 Approval Related Requirements**

Licence	Condition	Corresponding ESCP Section
CEAA, 2012	<p>3.8 The Proponent shall develop, prior to construction and in consultation with Indigenous groups and relevant authorities, measures to protect fish and fish habitat when undertaking activities in or near fish-bearing water bodies, in a manner that complies with any authorization issued under the Fisheries Act for the Designated Project. The Proponent shall implement these measures during all phases of the Designated Project. In doing so, the Proponent shall:</p> <p>3.8.3 maintain, during all phases of the Designated Project, a buffer of undisturbed vegetation of at least 30 meters from the high-water mark, as follows:</p> <p>3.8.3.1 around fish-bearing water bodies, including wetlands, within and adjacent to the Project development areas that are not required to be removed for construction of the Designated Project, in a manner that complies with any authorization issued under the Fisheries Act; and</p> <p>3.8.3.2 around wetlands, within and adjacent to the Project development areas that are not required to be removed for construction of the Designated Project, unless not technically or economically feasible. If work within 30 meters of wetlands is required, the Proponent shall use weight-distributing materials under machinery to limit soil compaction and give preference to using existing access roads to access areas near wetlands.</p>	3.0
CEAA, 2012	<p>3.11 The Proponent shall develop, prior to construction and in consultation with Indigenous groups and relevant authorities, and implement and maintain during all phases of the Designated Project, measures to control erosion and sedimentation within the Project development areas in a manner consistent with the Fisheries Act and its regulations, and taking into account Environment and Climate Change Canada’s Environmental Code of Practice for Metal Mines, and Fisheries and Oceans Canada’s Measures to Protect Fish and Fish Habitat. The Proponent shall submit these measures to the Agency before implementing them. As part of these measures, the Proponent shall:</p> <p>3.11.1 install intake pipes pointing upwards and away from sediment; and</p> <p>3.11.2 equip contact water discharge pipes with diffusers.</p>	3.0
CEAA, 2012	<p>5.7 The Proponent shall undertake, in consultation with Indigenous groups and relevant authorities, progressive reclamation of areas disturbed by the Designated Project. In doing so, the Proponent shall:</p> <p>5.7.2 establish performance standards for reclaimed areas, including that the areas be self-sustaining, reduce establishment of weed species, restore native species assemblages, and reduce erosion of exposed soils.</p>	3.0
Environment Act Licence No. 3390 (Gordon)	<p>17. The licensee shall prepare, implement and continuously maintain in current status, the following plans for the development in a manner acceptable to the director: I) Erosion and Sediment Control Plan.</p> <p>25. The licensee shall, with respect to on-site earthen construction works, construct and maintain silt fences or other suitable erosion and sediment controls in the drainage routes transporting surface runoff off the property of the development until vegetation has been re-established on disturbed areas</p>	3.0

**LYNN LAKE GOLD PROJECT:  
EROSION AND SEDIMENT CONTROL PLAN**

Introduction  
January 30, 2025

Licence	Condition	Corresponding ESCP Section
Environment Act Licence No. 3391 (MacLellan)	17. The licensee shall prepare, implement and continuously maintain in current status, the following plans for the development in a manner acceptable to the director: l) Erosion and Sediment Control Plan.  26. The licensee shall, with respect to on-site earthen construction works, construct and maintain silt fences or other suitable erosion and sediment controls in the drainage routes transporting surface runoff off the property of the development until vegetation has been re-established on disturbed areas.	3.0

# LYNN LAKE GOLD PROJECT: EROSION AND SEDIMENT CONTROL PLAN

Environmental Setting  
January 30, 2025

## 2.0 ENVIRONMENTAL SETTING

The Project is in the Boreal Shield Ecozone, Churchill River Upland Ecoregion and Reindeer Lake Ecodistrict, which is characterized as a mosaic of coniferous forest, interspersed with wetlands, lakes, rivers and exposed bedrock that is relatively undisturbed by human activity, but forest fires are a large-scale natural disturbance (Smith et al. 1998).

Within the Ecoregion, Dystric Brunisolic soils are dominant on sandy acidic till, while Gray Luvisolic soils dominate on well to imperfectly drained clay deposits (Smith et al. 1998). Granitic rock outcrops are co-dominant in the area. Notable areas of shallow and deep organic Mesisols, Fibrisols and Cryosols are associated with basin bogs, peat plateau and veneer bogs. Wind erosion risk for both topsoil and subsoil is relatively high while water erosion risk is relatively low at both the Gordon and MacLellan sites (Stantec 2017a). The landscape near the mine sites is flat to gently undulating, with most slopes ranging between 0 to 15% (Stantec 2017a). In general, waterbodies at both mine sites have  $\geq 30$  m of natural vegetation around them, except for the existing pits, or lakes immediately adjacent to the existing pits, at the Gordon site (Stantec 2017b).

## 2.1 POTENTIAL PROJECT EFFECTS

Erosion and sedimentation have the potential to affect soil quantity and quality, vegetation communities, and aquatic resources. Topsoil loss, a direct effect of erosion, removes important growth media from the environment and contributes to degradation of vegetation communities through nutrient leaching into local watersheds. The potential for invasive plant species (i.e., weeds) establishment and spread is also highest on disturbed or eroded sites which has potential to further reduce the diversity of the natural vegetation community. Noxious weeds such as common dandelion (*Taraxacum officinale*, a Tier 3 noxious weed in Manitoba; Department of Agriculture and Resource Development 2021) are known to occur at the Gordon site; noxious weeds have not been documented at the MacLellan site. With application of mitigation measures (including erosion and sediment controls) to help prevent soil loss and establishment of regulated weeds, the effect of soil loss and regulated weeds on community diversity is anticipated to be low.

Erosion can also negatively affect surface water quality by resulting in deposition of soil nutrients, sediment, and other debris (e.g., from soil stockpiles or cleared and disturbed sites) into aquatic environments, reducing the quality of those environments for fish, wildlife, and resource users. Numerous wetlands and creeks are found in the vicinity of the Project that could potentially be affected by a sediment release. Notable waterbodies adjacent to the Project with potential to be affected by erosion and sedimentation include the following (also see Maps 1 and 2, Appendix B for sensitive features in the vicinity of the Gordon and MacLellan site):

### *Gordon site*

- Gordon and Farley lakes at the mine site

## **LYNN LAKE GOLD PROJECT: EROSION AND SEDIMENT CONTROL PLAN**

Environmental Setting  
January 30, 2025

- Simpson and Swede lakes adjacent to the access road
- East and Wendy pits have the potential to be affected but will be dewatered during the construction phase.

### *MacLellan site*

- Keewatin River (flows from north to south and is the main tributary of Cockeram Lake downstream of the Project)
- Dot, Payne, and Minton lakes
- East Pond.

**LYNN LAKE GOLD PROJECT:  
EROSION AND SEDIMENT CONTROL PLAN**

Mitigation and Management Measures  
January 30, 2025

### 3.0 MITIGATION AND MANAGEMENT MEASURES

The mitigation measures listed below were developed as part of the EIS and are summarized by Project phase in Sections 3.1 to 3.4. The ESCP requirements are similar for each mine site and apply to both the Gordon and MacLellan sites. These mitigation measures proposed are to be considered as generalized guidance and as a toolbox for development of the site-specific plans to be completed by the Contractor and are generally considered to be industry standards effective for use in similar applications and environmental conditions. Detailed site-specific measures relevant to the Gordon and MacLellan sites require planning details that will not be available until tender of the Project and selection of the Contractor and will be completed by the Contractor as a part of their site-specific Contractor’s Erosion and Sediment Control Plan (CESCP). The CESCP will be reviewed by a Certified Professional in Erosion and Sediment Control (CPESC), for areas where work involves a high-risk area (see Maps 3 and 4, Appendix B) prior to implementation. For all other areas that are not considered high-risk, the CESCP will be reviewed by Alamos’ Environmental Department prior to implementation. Maps 3 and 4 (Appendix B) were developed using desktop data and serve as general guidance. Final CESCPs will account for changing conditions during construction, which may alter the erosion risk classification in specific areas, particularly after vegetation clearing. All CESCPs will incorporate adaptive mitigations to address "on-the-ground" variability in site conditions.

Site-specific mitigation measures and management practices for surface water are described in the SWMMP. Mitigation and management measures related specifically to wind erosion are captured in the AQMMP. Industry best management practices (BMPs) that will provide additional mitigation and management measures are described in Section 3.4.

### 3.1 CONSTRUCTION

Mitigation measures for reducing potential effects from Project activities that may result in erosion and/or sedimentation during the construction phase are summarized in Table 3-1. Details on where, when, and how specific mitigations will be installed will be included in the site-specific CESCP, to be developed as a part of the tendering process.

**Table 3-1 Mitigation Measures for Erosion and Sediment Control during Construction**

Item	Mitigation Measures
Administrative controls	<ul style="list-style-type: none"> <li>• The Contractor will be responsible for creating and submitting a site-specific CESCP as a part of the tendering process, including detail specific to the construction operations for the Project for mitigations during:               <ul style="list-style-type: none"> <li>– clearing/grubbing</li> <li>– soil salvage, handling, and storage</li> <li>– construction of cut/fill slopes, temporary access roads, ditches, culverts, etc.</li> <li>– excavation of borrow areas/dugouts</li> <li>– landscaping.</li> </ul> </li> </ul>

**LYNN LAKE GOLD PROJECT:  
EROSION AND SEDIMENT CONTROL PLAN**

Mitigation and Management Measures  
January 30, 2025

Item	Mitigation Measures
Administrative controls (cont'd)	<ul style="list-style-type: none"> <li>• The Contractor will include shutdown contingencies in their CЕССP for erosion and sediment control during planned or unplanned shutdowns in all seasons.</li> <li>• To assist in developing site-specific measures in the CЕССP, Erosion Risk Maps (Maps 3 and 4, Appendix B) have been created which incorporate:               <ul style="list-style-type: none"> <li>– sensitive areas within and adjacent to the Project (i.e., wetlands and waterbodies) by increasing the risk rating of the soil polygons within the Project footprint by one level (e.g., risk would go from very low to low if within 50 m of a waterbody or wetland feature).</li> <li>– calculated erosion risk of soil affected by the Project for both wind and water erosion, which includes variables for soil erodibility, slope steepness and length, and regional climate/rainfall (Stantec 2017a).</li> </ul> </li> <li>• anticipated surface water flow direction.</li> </ul>
Vegetation clearing	<ul style="list-style-type: none"> <li>• Mitigations are to be applied where and when vegetation clearing is required.</li> <li>• Schedule vegetation clearing activities to occur during dry or frozen conditions, when possible<sup>1</sup>. If clearing must occur in non-ideal conditions (e.g., on saturated or wet soil that is prone to compaction), construction matting will be used<sup>1</sup>.</li> <li>• Ground level cutting/mowing/mulching of wetland vegetation instead of grubbing will be conducted where possible<sup>1</sup>.</li> <li>• Riparian zones within which heavy machinery is prohibited from entering without prior approval<sup>2</sup> will be identified and flagged.</li> </ul>
Disturbed soils	<ul style="list-style-type: none"> <li>• Mitigations are to be included where and when soil disturbance is required.</li> <li>• Soil salvage activities will commence after vegetation clearing in a timely manner. The extent of vegetation clearing, when feasible, will be limited to areas where soil salvage is planned and can occur promptly to minimize the risk of soil erosion.</li> <li>• Soil handling during soil salvage will occur in dry conditions whenever possible and will cease if conditions are likely to result in soil erosion (e.g., heavy rain or wind). Soil will not be salvaged under frozen conditions unless it can be shown that no admixing will occur (mixing of soil profile layers).</li> <li>• Soil erosion from stockpiles will be managed by limiting the height and slope of stockpiles to 3:1 (horizontal to vertical).</li> <li>• Erosion control will be implemented as soon as possible after soil disturbance activities are complete. Exposed soils and soil stockpiles will be stabilized (e.g., slope texturing/track-walking, mulching, rolled erosion control product) and revegetated as necessary to reduce wind and water erosion.</li> <li>• Erosion and sediment control measures will be maintained in all disturbed sites until soils have stabilized and complete revegetation of all disturbed areas is achieved as approved by the Alamos' Environmental Department.</li> </ul>
Working near water	<ul style="list-style-type: none"> <li>• Must receive approval from Alamos' Environmental Department prior to commencing any work near or in water.</li> <li>• Mitigations are to be applied where and when working near water is required.</li> <li>• Sensitive areas, such as wetlands that are not required to be removed for construction of the Project, will be buffered by 30 m and clearly marked prior to clearing<sup>1</sup>.</li> <li>• Identifying and flagging riparian zones within which heavy machinery is prohibited from entering<sup>2</sup>. Some wetlands will be in-filled/affected by Project construction, and disturbance to wetlands not required to be removed for the construction of the Project will be prohibited, including a minimum 30 m buffer of undisturbed vegetation around the wetland.</li> </ul>

**LYNN LAKE GOLD PROJECT:  
EROSION AND SEDIMENT CONTROL PLAN**

Mitigation and Management Measures  
January 30, 2025

Item	Mitigation Measures
Working near water (cont'd)	<ul style="list-style-type: none"> <li>• Perimeter control will be installed and maintained to help to protect against deleterious substances entering adjacent wetlands or waterbodies<sup>1</sup>.</li> <li>• A protective layer such as matting or biodegradable geotextile and clay ramps or other approved materials will be used between wetland root/seed bed and construction equipment if ground conditions are encountered that create potential for rutting, admixing or compaction<sup>1</sup>.</li> <li>• Frost packing, snow, ice, geotextile swamp mats or access mats will be used for access through wet areas<sup>1</sup>.</li> <li>• Perimeter and access road grading will divert runoff away from the open pits and fish-bearing waterbodies<sup>2</sup>.</li> <li>• Erosion and sediment control measures will be implemented during construction to reduce increases in total suspended solids (TSS) concentrations in lakes and streams<sup>2</sup>.</li> <li>• Disturbance areas around waterbodies will be limited to maintain existing riparian vegetation and promote recovery of riparian vegetation by marking buffer zones around sensitive habitats and work areas; using existing access routes; reducing soil compaction by using weight-distributing materials under machinery<sup>2</sup>.</li> <li>• In-water works will be limited to outside of the northern Manitoba Restricted Activity Timing Windows for the Protection of Fish and Fish Habitat (spring [April 15 to June 30], summer [May 15 to July 15], and fall [September 1 to May 15]; DFO 2020) unless otherwise approved in writing by relevant authorities.<sup>2</sup></li> <li>• In-water work areas will be isolated and fish salvage will be conducted prior to dewatering (see Fish Salvage Plan), including East Pond at the MacLellan site, Wendy and East pits at the Gordon site, and any other locations where instream construction will be required<sup>2</sup>.</li> <li>• Intake pipes will point upward, away from sediment.</li> </ul>
On-site water management	<ul style="list-style-type: none"> <li>• On-site drainage will be incorporated into the Construction Design Drawings.</li> <li>• Non-contact water and on-site groundwater shall be diverted around or through the Project to prevent construction activities from affecting water quality.</li> <li>• Mitigations are to be applied where and when surface water management is required.</li> <li>• Grading within wetland boundaries will be reduced unless required for site-specific purposes<sup>1</sup>.</li> <li>• Grading will be directed away from wetlands, where possible<sup>1</sup>.</li> <li>• Cross drainage will be maintained to allow water to move freely from one side of the road to the other in areas of permanent or temporary access roads<sup>1</sup>.</li> <li>• Existing drainage patterns will be maintained to the extent possible with the use of culverts<sup>2</sup>.</li> <li>• Access roads will be maintained by periodically regrading and ditching to improve water flow and reduce erosion<sup>2</sup>.</li> <li>• Collection pond inlets and outlets will be designed to reduce water velocities, scour (erosion of sediment) and pond stratification potential (chemical or thermal).</li> <li>• Culverts will be maintained in access road crossings to remove accumulated material and debris to reduce erosion, flooding, and sediment mobilization<sup>2</sup>.</li> <li>• On-site drainage areas will be designed to be as small as possible to limit stormwater flow volumes.</li> <li>• Perimeter and contact-water collection ditches will be constructed to collect overland flow, toe seepage, and groundwater recharge, and to divert non-contact water away from the Project components<sup>3</sup>.</li> </ul>

**LYNN LAKE GOLD PROJECT:  
EROSION AND SEDIMENT CONTROL PLAN**

Mitigation and Management Measures  
January 30, 2025

Item	Mitigation Measures
On-site water management (cont'd)	<ul style="list-style-type: none"> <li>• Contact-water collection ditches and culverts are designed to safely convey the peak flow resulting from the 25-year, 24-hour rainfall event, with positive gradients to limit standing water and maintain positive flow<sup>3</sup>. Given the life of mine, the 25-year event was considered adequate for the sizing of the on-site water management.</li> <li>• Surface water quality will be monitored on a regular basis and after rainfall or snowmelt events.</li> <li>• Contact water discharge pipes will be equipped with diffusers.</li> </ul>
Revegetation	<ul style="list-style-type: none"> <li>• A native seed mix will be used to assist in reducing the spread and establishment of invasive plant species as well as for erosion control on exposed soils<sup>1</sup>. Cover crops that consist of short-growing (non-native) annual species such as oats may be used in areas that require immediate soil stabilization or to control aggressive non-native invasive species (see Vegetation and Weed Management Plan). However, how annual cover crops attract wildlife (e.g., food source) should be considered.</li> </ul>
<p>Notes:</p> <p><sup>1</sup> Assessment of Potential Effects on Vegetation and Wetlands (Stantec 2020a)</p> <p><sup>2</sup> Assessment of Potential Effects on Fish and Fish Habitat (Stantec 2020b)</p> <p><sup>3</sup> Assessment of Potential Effects on Surface Water (Stantec 2020c)</p>	

### 3.2 OPERATION

Mitigation measures for reducing potential effects from Project activities that may result in erosion and/or sedimentation during the operation phase are summarized in Table 3-2.

**Table 3-2 Mitigation Measures for Erosion and Sediment Control during Operation**

Item	Mitigation Measures
Working near water	<ul style="list-style-type: none"> <li>• Must receive approval from Alamos' Environmental Department prior to commencing any work near or in water.</li> <li>• Mitigations are to be applied where and when working near water is required.</li> <li>• Silt fencing will be installed and maintained to reduce deleterious substances from entering adjacent to wetlands or waterbodies<sup>1</sup>.</li> </ul>
On-site water management	<ul style="list-style-type: none"> <li>• Mitigations are to be applied where and when surface water management is required.</li> <li>• Cross drainage will be maintained to allow water to move freely from one side of the road to the other in areas of permanent or temporary access roads<sup>1</sup>.</li> <li>• Access roads will be maintained by periodically regrading and ditching to improve water flow and reduce erosion<sup>2</sup>.</li> <li>• Collection pond inlets and outlets will be designed to reduce water velocities, scour (erosion of sediment) and pond stratification potential (chemical or thermal).</li> <li>• Culverts in access road crossings will be maintained to remove accumulated material and debris to reduce erosion, flooding, and sediment mobilization<sup>2</sup>.</li> <li>• Water management facilities will be designed to collect and treat (as required) contact water such that effluent meets applicable federal and provincial regulatory requirements, including the authorized limits of deleterious substances specified in Schedule 4 of the Metal and Diamond Mining Effluent Regulations (amended), prior to discharge to the environment<sup>3</sup>.</li> </ul>

**LYNN LAKE GOLD PROJECT:  
EROSION AND SEDIMENT CONTROL PLAN**

Mitigation and Management Measures  
January 30, 2025

**Table 3-2 Mitigation Measures for Erosion and Sediment Control during Operation**

Item	Mitigation Measures
On-site water management (cont'd)	<ul style="list-style-type: none"> <li>• Sediment control will be in place in site collection ponds prior to discharging into the receiving waterbody<sup>4</sup>.</li> <li>• Surface water quality will be monitored on a regular basis and after rainfall or snowmelt events.</li> </ul>
<p>Notes:</p> <p><sup>1</sup> Assessment of Potential Effects on Vegetation and Wetlands (Stantec 2020a)</p> <p><sup>2</sup> Assessment of Potential Effects on Fish and Fish Habitat (Stantec 2020b)</p> <p><sup>3</sup> Assessment of Potential Effects on Surface Water (Stantec 2020c)</p> <p><sup>4</sup> Water Management Feasibility Level Design Report (Golder Associates Ltd. 2020)</p>	

### 3.3 DECOMMISSIONING/CLOSURE/POST CLOSURE

Mitigation measures for reducing potential effects from Project activities that may result in erosion and/or sedimentation during the decommissioning/closure/post closure phase are summarized in Table 3-3. These mitigations are to be considered as a toolbox for the decommissioning/closure/post closure process.

**Table 3-3 Mitigation Measures for Erosion and Sediment Control during Decommissioning/Closure/Post Closure**

Item	Mitigation Measures
On-site water management	<ul style="list-style-type: none"> <li>• Mitigations are to be applied where and when surface water management is required.</li> <li>• Perimeter sediment control (e.g., silt fence, sediment retention fiber roll, diversion ditches/berms) will be installed and maintained to reduce deleterious substances from entering adjacent to wetlands or waterbodies<sup>1</sup>.</li> <li>• A protective layer such as matting or biodegradable geotextile and clay ramps or other approved materials will be used between wetland root/seed bed and construction equipment if ground conditions are encountered that create potential for rutting, admixing or compaction<sup>1</sup>.</li> <li>• Perimeter and access roads will be graded to divert runoff away from the open pits and fish-bearing waterbodies<sup>2</sup>.</li> </ul>
On-site water flow	<ul style="list-style-type: none"> <li>• Must receive approval from Alamos' Environmental Department prior to commencing any work near or in water.</li> <li>• Mitigations are to be applied where and when surface water management is required.</li> <li>• Grading within wetland boundaries will be reduced unless required for site-specific purposes<sup>1</sup>.</li> <li>• Grading will be directed away from wetlands, where possible<sup>1</sup>.</li> <li>• Cross drainage will be maintained to allow water to move freely from one side of the road to the other in areas of permanent or temporary access roads<sup>1</sup>.</li> <li>• Access roads will be maintained by periodically regrading and ditching to improve water flow and reduce erosion<sup>2</sup>.</li> </ul>

**LYNN LAKE GOLD PROJECT:  
EROSION AND SEDIMENT CONTROL PLAN**

Mitigation and Management Measures  
January 30, 2025

Item	Mitigation Measures
On-site water flow (cont'd)	<ul style="list-style-type: none"> <li>• Culverts in access road crossings will be maintained to remove accumulated material and debris to reduce erosion, flooding, and sediment mobilization<sup>2</sup>.</li> <li>• Surface water quality will be monitored on a regular basis and after rainfall or snowmelt events.</li> </ul>
Revegetation	<ul style="list-style-type: none"> <li>• A native seed mix will be used to assist in reducing invasive plant species spread and establishment as well as for erosion control on exposed soils<sup>1</sup>.</li> <li>• Native areas disturbed by the Project will be reseeded using a native upland seed mix; however, the TMF will be capped and seeded with a reclamation seed mix in accordance with the Closure Plan.</li> </ul>
Notes:	
<sup>1</sup> Assessment of Potential Effects on Vegetation and Wetlands (Stantec 2020a)	
<sup>2</sup> Assessment of Potential Effects on Fish and Fish Habitat (Stantec 2020b)	

### 3.4 BEST MANAGEMENT PRACTICES

Erosion and sediment control BMPs are used to reduce erosion potential of exposed soils and reduce surface water runoff velocities. The suitability of BMPs vary by site-specific factors, such as substrate material, time of year, site conditions (e.g., slope), and expected risk. Experience and the adaptive management framework (Section 5.0) will be used in the selection and application of BMPs and overall implementation of the ESCP. Typical BMPs that will be used for the Project are summarized in Table 3-4 and described in greater detail in Appendix A. These mitigations are to be considered as a toolbox for development of the Contractor’s construction ESCP, to be included in the tendering process.

**Table 3-4 Best Management Practices for Erosion and Sediment Control**

Best Management Practice	Applications				Description
	Slopes	Ditches and Channels	Flat Surface Areas	Borrow and Stockpile Areas	
Silt fence	✓	–	✓	✓	A short-term sediment control measure commonly used to allow water to pond and settle out coarse-grained sediment. Used only in areas of sheet flow (not to be installed in areas of concentrated flow). Removal of sediment is required once it reaches 1/3 of the height of the installed silt fence. Should the silt fence no longer be required (i.e. upon revegetation of the site) removal of silt fence is to be completed by cutting the silt fence material at ground surface and removing the stakes.

**LYNN LAKE GOLD PROJECT:  
EROSION AND SEDIMENT CONTROL PLAN**

Mitigation and Management Measures  
January 30, 2025

Best Management Practice	Applications				Description
	Slopes	Ditches and Channels	Flat Surface Areas	Borrow and Stockpile Areas	
Sediment retention fiber roll	✓	✓	✓	✓	A short, medium, and long-term sediment control measure using a biodegradable roll of coarse containment material filled with straw, mulch, or wood fiber. May be used in areas of sheet flow or concentrated flow, on slopes (to reduce slope length) and in drainage channels or inlets (as checks to reduce flow velocity or help to retain sediment). May be vegetated and left in place if site maintenance requirements allow. Is to be installed as per manufacturer's recommendations with staking patterns as per the intended use of the product.
Ditch check	–	✓	–	✓	A medium- to long-term sediment control measure using gabion baskets, rock check dams, synthetic permeable berms, sediment retention fibre rolls, etc. to create a flow-through or drop structure for reducing water flow and increasing ponding and sediment settling. Installation of these structures requires a rolled erosion control product to be installed concurrently, as per manufacturer's recommendations.
Continuous perimeter control	–	✓	✓	✓	A medium- to long-term sediment control measure used to convey intercepted surface water runoff to a desirable collection (e.g., sediment basin). Ditches are not to convey water directly into a natural waterbody (e.g., wetland or stream). Used in conjunction with drainage ditches to manage on-site surface water (see the SWMMMP).
Berm interceptor	✓	–	✓	✓	A short- to long-term sediment control measure used to intercept, direct, and/or slow surface water runoff. Used in conjunction with diversion ditches to manage on-site surface water (see the SWMMMP). Construction of berm interceptors is to be consistent with anticipated flow and volume of surface water at the design location; sufficient material and surface protection of the berm is to be used to prevent erosion of the berm by Project surface water.
Rolled erosion control product	✓	✓	✓	✓	A biodegradable blanket that is rolled on to the ground surface and anchored in place, used as a medium- to long-term erosion and sediment control measure when paired with revegetation efforts (e.g., seeding). This product is to be installed as per manufacturer's recommendations, with stapling patterns to be followed depending on the intended use and location of the product.
Riprap armouring	-	✓	–	–	A short- to long-term erosion control measure used to reduce scouring and erosion from high velocity water flow where vegetation is not easily established. May only be used in potential fish habitat if approvals are obtained. Requires installation of a geotextile base material prior to riprap placement.

**LYNN LAKE GOLD PROJECT:  
EROSION AND SEDIMENT CONTROL PLAN**

Mitigation and Management Measures  
January 30, 2025

Best Management Practice	Applications				Description
	Slopes	Ditches and Channels	Flat Surface Areas	Borrow and Stockpile Areas	
Sediment basin	–	✓	–	✓	A medium- to long-term sediment control measure used to capture surface water runoff and promote settling of suspended sediment. Used in conjunction with diversion ditches to manage on-site surface water (see the SWMMP). Sediment basins shall be designed with size and shape to handle anticipated surface water volumes.
Pumped silt control system (sediment bag)	–	–	✓	–	A short-term sediment control measure, to be used when dewatering sediment laden water into well vegetated areas. Requires continuous monitoring and regular replacement when full of sediment.
Seeding and hydroseeding	✓	✓	✓	✓	A medium- to long-term erosion control measure. The effectiveness increases with time as vegetation develops but typically requires surface preparation and maintenance (see the Vegetation and Weed Management Plan for seeding prescriptions). May be used in conjunction with Biotic Soil Growth Medium. Requires hydroseeding heavy equipment and access for at least two application directions.
Mulching and hydromulching	✓	–	✓	✓	A short- to medium-term erosion control measure to reduce erosion from rain and promoting plant growth (e.g., thermal protection and moisture retention) and slope protection.
Biotic soil media	✓	✓	✓	✓	An alternative to topsoil and mulch, a medium- to long-term measure for soil building and vegetation establishment. Can be applied hydraulically with seed for erosion control and as a soil replacement/amendment.
Live staking	✓	✓	✓	–	A long-term erosion and sediment control measure used to establish shrub and tree cover and below-ground root structure to improve bank stability and reduce erosion potential (see the Vegetation and Weed Management Plan for planting prescriptions).
Surface roughening and slope texturing	✓	–	✓	✓	A short- to medium-term erosion and sediment control measure used to roughen exposed substrates to reduce erosion potential by increasing water infiltration and sediment capture. Should track-walking by heavy equipment be employed, the equipment is to track perpendicular to the slope.
<p>Notes:</p> <ul style="list-style-type: none"> <li>✓ Situations where a BMP is applicable.</li> <li>– Situations where a BMP is not applicable.</li> </ul>					

**LYNN LAKE GOLD PROJECT:  
EROSION AND SEDIMENT CONTROL PLAN**

Monitoring  
January 30, 2025

## **4.0 MONITORING**

Monitoring (follow-up) is the continuation of observation, measurement, or assessment of environmental conditions at and surrounding the Project, its components, or activities. Two types of monitoring are typically undertaken for environmental assessments: environmental monitoring to verify the accuracy of predictions and implemented mitigation measures; and compliance monitoring for verification of practices or procedures to meet legislated requirements. Components to be monitored have been determined based on regulatory instrument requirements as per legislation, environmental importance, sensitivity and vulnerability, and licence requirements.

Monitoring plans describe sampling procedures, quality control and assurance programs, laboratory methods and protocols, laboratory accreditations, and reporting requirements where applicable. The plans also provide details on the location, design, methods (e.g., parameters to be measured), applicable regulatory instruments, and schedule for the follow-up and monitoring programs. Engagement of Indigenous Nations in monitoring is incorporated into the monitoring plans where appropriate and applicable. Detailed site-specific monitoring plans for the construction phase will be included in the CESC.

Monitoring activities throughout the construction, operation, and decommissioning/ closure phases include monitoring of work areas, monitoring of ditches, stockpiles, and other earthworks, and water quality monitoring for total suspended solids. These activities are described in greater detail below, by phase, to assist the Contractor in developing site-specific monitoring plans within their CESC, to be completed in the tendering process, and are assumed to be the same for both mine sites, where applicable. All water quality monitoring is outlined in the SWMMP, including details on turbidity and total suspended solids (TSS) monitoring. For TSS/turbidity monitoring, the calibration curve calculation is included as a part of the SWMMP. All air quality monitoring is outlined in the AQMMP, including details on wind erosion monitoring. Monitoring or inspection forms used during the Project are to be submitted for review to Alamos prior to any on-site activities.

The specific and measurable end points for concluding the monitoring program will be set to ensure the accuracy of the environmental assessment and the effectiveness of mitigation measures. These end points will be achieved either at permanent closure or earlier if it can be demonstrated that there are no further impacts warranting continued monitoring.

## **4.1 CONSTRUCTION**

### **4.1.1 Monitoring of Vegetation Clearing and Sensitive Area Demarcation**

Monitoring of vegetation clearing activities prior to ground disturbance and marking of sensitive areas will be conducted continuously during the construction phase of the Project by Alamos' Environmental Department and by Contractors, to identify risks associated with construction activities. BMPs required for the construction phase are required to be proactively applied to work areas prior to construction, and the installation of those practices will be monitored daily or weekly, as appropriate. Additionally, all sensitive

**LYNN LAKE GOLD PROJECT:  
EROSION AND SEDIMENT CONTROL PLAN**

Monitoring  
January 30, 2025

areas where construction activities are prohibited will be marked (e.g., historical resources, riparian zones, sensitive soils, rare plants, wildlife setbacks, etc.). The adaptive management framework (Section 5.0) will be used to adjust and modify the application of BMPs as required. Monitoring frequency may be reduced under frozen ground conditions (i.e., in winter). Table 4-1 provides a summary of the monitoring activities for the ESCP.

**Table 4-1 Summary of Monitoring Activities for the Erosion and Sediment Control Plan**

<b>Monitoring Activity</b>	<b>Project Phase</b>	<b>Frequency</b>	<b>Season</b>
Monitoring of work areas	Construction, and Decommissioning	Daily and after significant rainfall (>12 mm in a 24-hour period) and/or snowmelt events	Year-round <sup>1</sup>
Monitoring of ditches, stockpiles, dewatering activities, and other earthworks	Construction, Operation, and Decommissioning	Daily or weekly depending on active construction scheduling and rainfall/snowmelt events	Year-round <sup>1</sup>
Water quality monitoring for total suspended solids	Construction, Operation, and Decommissioning	See the SWMMP	See the SWMMP
Note: <sup>1</sup> May be reduced under dry or frozen conditions.			

**4.1.2 Monitoring of Work Areas**

General monitoring of the active construction areas (see Table 4-1) will be conducted full-time throughout the construction phase by the Alamos’ Environmental Department and by Contractors to identify risks associated with erosion and sedimentation. BMPs will be proactively applied to work areas and the effectiveness of those practices will be monitored daily, particularly prior to and following large rainfall events (>12.5 mm in a 24-hour period), storms, and spring snow melt. The adaptive management framework (Section 5.0) will be used to adjust and modify the application of BMPs as required. Monitoring frequency may be reduced under frozen ground conditions (i.e., in winter). Table 4-1 provides a summary of the monitoring activities for the ESCP.

**4.1.3 Monitoring of Ditches, Stockpiles, Dewatering Activities, and other Earthworks**

Monitoring of ditches, stockpiles, dewatering activities, and other earthworks activities will be conducted throughout the construction phase by the Alamos’ Environmental Department and by Contractors to identify risks associated with erosion and sedimentation. BMPs will be proactively applied to work areas and the effectiveness of those practices will be monitored daily or weekly, as appropriate. The adaptive management framework (Section 5.0) will be used to adjust and modify the application of BMPs as required. Monitoring frequency may be reduced under frozen ground conditions (i.e., in winter). Table 4-1 provides a summary of the monitoring activities for the ESCP.

**LYNN LAKE GOLD PROJECT:  
EROSION AND SEDIMENT CONTROL PLAN**

Monitoring  
January 30, 2025

#### **4.1.4 Water Quality Monitoring for Total Suspended Solids**

Water quality monitoring for the Project, including for TSS and turbidity, will be undertaken as part of the Surface Water Monitoring Program. As such, the details associated with the monitoring of TSS and turbidity (including creation of a turbidity calibration curve for measuring turbidity in the field) are included in the SWMMP. It is expected that TSS and turbidity monitoring will occur as part of a regularly scheduled monitoring program with additional monitoring following large rainfall (e.g., >12.5 mm in a 24-hour period) or snowmelt events and will incorporate multiple on-site and control locations to adequately compare Project TSS and turbidity levels with background surface water quality variability. Table 4-1 provides a summary of the monitoring activities for the ESCP. Additional surface water monitoring activities, including during the construction phase of the Project are included in the SWMMP.

### **4.2 OPERATION**

#### **4.2.1 Monitoring of Ditches, Stockpiles, and other Earthworks**

Monitoring of earthwork activities (including ditches and stockpiles) where ground disturbance is ongoing will be conducted throughout the operation phase. Table 4-1 provides a summary of the monitoring activities for the ESCP.

#### **4.2.2 Water Quality Monitoring for Total Suspended Solids**

Water quality monitoring for TSS will be conducted throughout the operation phase. Table 4-1 provides a summary of the monitoring activities for the ESCP.

### **4.3 DECOMMISSIONING/CLOSURE/POST CLOSURE**

#### **4.3.1 Monitoring of Work Areas**

General monitoring of decommissioning and closure activities will be conducted throughout the decommissioning phase. Table 4-1 provides a summary of the monitoring activities for the ESCP.

#### **4.3.2 Monitoring of Ditches, Stockpiles, and other Earthworks**

Monitoring of earthwork activities where ground disturbance is ongoing will be conducted throughout the decommissioning phase. Table 4-1 provides a summary of the monitoring activities for the ESCP.

#### **4.3.3 Water Quality Monitoring for Total Suspended Solids**

Water quality monitoring for TSS will be conducted throughout the decommissioning phase. Table 4-1 provides a summary of the monitoring activities for the ESCP.

**LYNN LAKE GOLD PROJECT:  
EROSION AND SEDIMENT CONTROL PLAN**

Adaptive Management  
January 30, 2025

## **5.0 ADAPTIVE MANAGEMENT**

Adaptive management is a planned process for responding to uncertainty or to an unanticipated or underestimated project effect by incorporating procedures and actions to planned monitoring and subsequent mitigation reviews. It is intended to continuously improve Project environmental management by reviewing mitigation outcomes and developing additional mitigation depending on the results of Project monitoring. As such, information learned from monitoring actual project effects is applied and compared to predicted effects. Where a variance between the actual and predicted effects occurs, a determination is made as to whether modifications or other actions are necessary to revise the existing mitigation measures. As part of this commitment, technically and economically feasible mitigation measures will be implemented if monitoring indicates that levels of environmental change have been reached or exceeded. Feasibility and implementation decisions will be made based on the circumstances and considerations at the time. Prior to construction, the Contractor shall include an adaptive management framework to their planned monitoring activities, which will include specific monitoring locations and timing, with triggers and potential responses based on low, medium, and high levels of environmental risk related to erosion and sedimentation. These levels will in part be developed during the Contractor's planning process and will be informed by the Erosion Risk Map (see Table 3-1 and Maps 3 and 4, Appendix B). After the start of construction, this framework will guide the development of adaptive management responses for operation.

### **5.1 THRESHOLDS FOR ADAPTIVE MANAGEMENT**

Thresholds for adaptive management for the monitoring of TSS and turbidity are established in the SWMMP in accordance with regulatory limits. See the SWMMP for details; however, the performance of ESCP mitigation measures and BMPs, as they relate to all monitoring activities, will be continually evaluated by Alamos' on-site Environmental Department, and by Contractors, whose discretion will be used to employ adaptive management to address immediate and long-term erosion or sedimentation concerns. Thresholds related to response levels for erosion and sedimentation concerns (low, medium, and high risk) will be developed as a part of the CЕСP prior to construction and will be included in the site-specific monitoring details.

**LYNN LAKE GOLD PROJECT:  
EROSION AND SEDIMENT CONTROL PLAN**

Reporting  
January 30, 2025

## **6.0 REPORTING**

Alamos will develop an annual monitoring report summarizing the erosion and sediment control monitoring results that will be shared with interested Indigenous Nations, stakeholders, and relevant regulatory bodies. The annual reporting will include adaptive management actions that were taken, and/or decision thresholds/triggers that were reached during that year. Any exceedance of compliance thresholds will be reported to the relevant regulatory authorities and Indigenous Nations at the time of the exceedance.

In addition to ESCP monitoring activities, water quality monitoring results will be reported in the SWMMP and the results will be reviewed and used to evaluate the need for additional erosion and sediment control mitigation and/or monitoring.

## LYNN LAKE GOLD PROJECT: EROSION AND SEDIMENT CONTROL PLAN

References  
January 30, 2025

### 7.0 REFERENCES

- Alamos (Alamos Gold Inc.). 2023. 2022 Report on Conformance to the Responsible Gold Mining Principles. Available at: [https://s24.g4cdn.com/779615370/files/doc\\_downloads/rgmp/AGI-2022-RGMP-Report-Final.pdf](https://s24.g4cdn.com/779615370/files/doc_downloads/rgmp/AGI-2022-RGMP-Report-Final.pdf). (Accessed April 2024)
- CCME (Canadian Council of Ministers of the Environment). 2002. Canadian water quality guidelines for the protection of aquatic life – total particulate matter. CCME, Hull, QC. Available at: <http://cegg-rcqe.ccme.ca/download/en/217/>. Accessed March 2021.
- Department of Agriculture and Resource Development. 2021. Declaration of noxious weeds. Government of Manitoba, Department of Agriculture and Resource Development. Available at: <https://www.gov.mb.ca/agriculture/crops/weeds/declaration-of-noxious-weeds-in-mb.html>. Accessed March 2021.
- DFO (Fisheries and Oceans Canada). 2020. Manitoba restricted activity timing windows for the protection of fish and fish habitat. Available at: <https://www.dfo-mpo.gc.ca/pnw-ppe/timing-periodes/mb-eng.html>. Accessed March 2021.
- Golder Associates Ltd. 2020. Water management feasibility level design report: Lynn Lake Gold Project. Prepared for Alamos Gold Inc. Winnipeg, MB.
- Government of Alberta. 2011. Erosion and sediment control manual. Government of Alberta, Ministry of Transportation. Edmonton, AB.
- MWS (Manitoba Water Stewardship). 2011. Manitoba water quality standards, objectives, and guidelines. Report 2011-01, 72 pp. Water Science and Management Branch, Manitoba Water Stewardship, Winnipeg, MB.
- Smith, R., H. Veldhuis, G. Mills, R. Eilers, W. Fraser and G. Lelyk. 1998. Terrestrial ecozones, ecoregions, and ecodistricts of Manitoba: an ecological stratification of Manitoba's natural landscapes. Technical Bulletin 98-9E. Land Resource Unit, Brandon Research Center, Research Branch. Agriculture and Agri-Food Canada. Winnipeg, Manitoba.
- Stantec (Stantec Consulting Ltd.). 2017a. Lynn Lake Gold Project (LLGP): soil and terrain baseline technical data report – 2015 terrestrial environment baseline program. Prepared for Alamos Gold Inc. May 2020. Winnipeg, MB.
- Stantec. 2017b. Lynn Lake Gold Project (LLGP): vegetation baseline technical data report – 2015 terrestrial environment baseline program. Prepared for Alamos Gold Inc. May 2020. Winnipeg, MB.
- Stantec. 2020a. Lynn Lake Gold Project Environmental Impact Statement volume 2, chapter 11 – assessment of potential effects on vegetation and wetlands. Prepared for Alamos Gold Inc. May 2020. Winnipeg, MB.

**LYNN LAKE GOLD PROJECT:  
EROSION AND SEDIMENT CONTROL PLAN**

References

January 30, 2025

Stantec. 2020b. Lynn Lake Gold Project Environmental Impact Statement volume 2, chapter 10 – assessment of potential effects on fish and fish habitat. Prepared for Alamos Gold Inc. May 2020. Winnipeg, MB.

Stantec. 2020c. Lynn Lake Gold Project Environmental Impact Statement volume 1, chapter 9 – assessment of potential effects on surface water. Prepared for Alamos Gold Inc. May 2020. Winnipeg, MB.

**LYNN LAKE GOLD PROJECT:  
EROSION AND SEDIMENT CONTROL PLAN**

Appendix A Best Management Practices  
January 30, 2025

## **Appendix A Best Management Practices**

## LYNN LAKE GOLD PROJECT: EROSION AND SEDIMENT CONTROL PLAN

Appendix A Best Management Practices  
January 30, 2025

The Government of Alberta (2011) has developed a comprehensive *Erosion and Sediment Control Manual* that outlines BMPs for mitigating and managing erosion and sedimentation associated with ground disturbance that is used in the ESCP because the Province of Manitoba does not have a similar guidance document. Copies of the relevant BMPs from the manual are provided here to guide application of the BMPs that will typically be used in the Project (see Section 3.4) and are:

- Silt fence (BMP# 1).
- Ditch check (BMPs# 2, 7, 10, 38).
- Continuous perimeter control (BMP# 4).
- Berm interceptor (BMP# 5).
- Rolled erosion control blanket (BMP# 13).
- Riprap armouring (BMPs# 14, 17).
- Sediment basin (BMP# 18).
- Seeding (BMPs# 22, 24).
- Mulching (BMPs# 23, 24).
- Live staking (BMP# 27).
- Pumped silt control systems (BMP# 31).
- Surface roughening and slope texturing (BMP# 34).

Silt Fence Sediment Control	B.M.P. #1
--------------------------------	-----------

### **Description and Purpose**

- Permeable fabric barriers installed vertically on support posts along contours to collect sediment laden sheet flow runoff
- Causes water to pond allowing sediment to settle out as water filters through fabric
- Entraps and minimizes coarse sediment from sheet flow or overland flow from entering waterbodies
- Perimeter control for sediment transport and deposition

### **Applications**

- Temporary measure
- Used at bottom of cut or fill slopes to collect sediment laden runoff
- Used along streams (or channels) banks
- Used around stockpiles
- Midslope grade-break (using "J-hook" or "smile" pattern to effect ponding, filtering and sedimentation)

### **Advantages**

- Low permeability silt fences have high filtering capabilities for fine sand to coarse silt
- Filter fence more effective than straw bales at filtering out sediment

### **Limitations**

- Applicable for sheet flow, cannot handle concentrated channel flow volumes
- May fail under high runoff events
- Limit to locations suitable for temporary ponding of sediment laden runoff
- Low permeability silt fences may not be strong enough to support weight of water retained behind it and may require reinforcement (i.e., wire mesh and stronger support)
- Sediment build up needs to be removed on a regular basis
- Damage to fence may occur during sediment removal
- Useable life of approximately one year dependent on regular maintenance

Silt Fence Sediment Control	B.M.P. #1
--------------------------------	-----------

### **Construction**

- Two methods of installation are commonly used
  - Trench method
  - Mechanical (slicing) installation method (e.g. Tommy Silt Fence Machine or equivalent)
- Trench Method
  - Select location of silt fence (usually along contours)
  - Drive support posts a minimum of 0.3 m into ground, spaced a maximum of 2 m apart
  - Excavate trench approximately 0.15 m deep by 0.15 m wide for entire length of fence along upstream side of posts
  - Attach the wire mesh or snow fencing, if used as reinforcement, to upstream side of posts with staples
  - Extend filter fabric to base of trench and attach over wire mesh or snow fence, if used, on upstream side of posts
  - Backfill and compact soil in trench, being careful not to damage fence
- Mechanical Installation Method
  - Select location of silt fence (usually along contours)
  - Use mechanical installation machine to embed the fabric a minimum of 0.15 m into the ground. One mechanical installation method is by slicing (with special equipment) the geotextile fabric embeds into the ground without excavation and backfill. There is only minor disturbance of the ground. Tamping of ground is required for compaction.
  - Drive support posts a minimum of 0.3 m into ground, spaced a maximum of 2 m apart
  - Attach the wire mesh or snow fencing, if used as reinforcement to silt fence fabric, to upstream side of posts with staples
  - Extend filter fabric to base of trench and attach over wire mesh or snow fence, if used, on upstream side of posts

### **Construction Considerations**

- Site Selection

## Silt Fence

## Sediment Control

B.M.P. #1

- Size of drainage area should be no greater than 0.1 ha per 30 m length of silt fence
- Maximum flow path length above silt fence should be no greater than 30 m
- Maximum slope gradient above the silt fence should be no greater than 2H:1V
- Fence should be placed on contour to produce proper ponding
- Fence should be placed far enough away from toe of slope to provide adequate ponding area (minimum of 1.8 m away from toe of slope is recommended)
- Ends of fence should be angled upslope to collect runoff
- Fence should not extend more than 0.6 m above grade
- Posts can be wood or metal material dependent on design and ground conditions
- Posts should be placed on downstream side of fence
- Posts should not be spaced greater than 2 m apart
- Wire mesh or standard snow fencing may be placed between the posts and fabric barrier to provide additional strength and support reinforcement
- Geotextile should be cut from a continuous roll to avoid joints (if joints are necessary, the wrapping of fabric around the fence post and a minimum overlap of 0.2 m with staples should be used to attach the fabric to the post)
- Fence (and wire mesh or snow fence, if used) should be attached to posts with heavy duty staples, tie wires, or hog rings
- Fence (and wire mesh or snow fence, if used) should be dug into a trench at least 0.15 m deep to prevent undercutting of fence by runoff
- Trench backfill should be compacted
- Long runs of silt fence are more prone to failure than short runs
  - Maximum length of each section of silt fence should be 40 m
  - Silt fence should be installed in 'J' hook or 'smile' configuration, with maximum length of 40 m, along contours allowing an escape path for ponded water (minimizes overtopping of silt fence structure)

### **Inspection and Maintenance**

- Inspection frequency should be in accordance with the PESC and TESC Plans
- Repair undercut fences and repair or replace split, torn, slumping or weathered fabric immediately

Silt Fence Sediment Control	B.M.P. #1
--------------------------------	-----------

- Sediment build up should be removed once it accumulates to a depth of 0.2 m
- Remove fence after vegetation is established
- Deactivate fabric by cutting-off top portion of fabric above ground; bottom trenched-in portion of fence fabric can be left in-ground thus minimizing ground disturbance

#### **Similar Measures**

- Straw Bales
- Rock Barrier
- Permeable/Synthetic Barriers

#### **Design Considerations**

- For a silt fence system to work as a system, the following factors should be considered:
  - a) quantity – adequate number and frequency of fence for efficient ponding and sedimentation
  - b) installation – workmanship
  - c) compaction – backfill and trenching of fabric
  - d) support – posts adequately embedded, appropriate selection of post material and spacing
  - e) attachment – secure fabric to post
- Install silt fences in a 'J' hook or 'smile' configuration

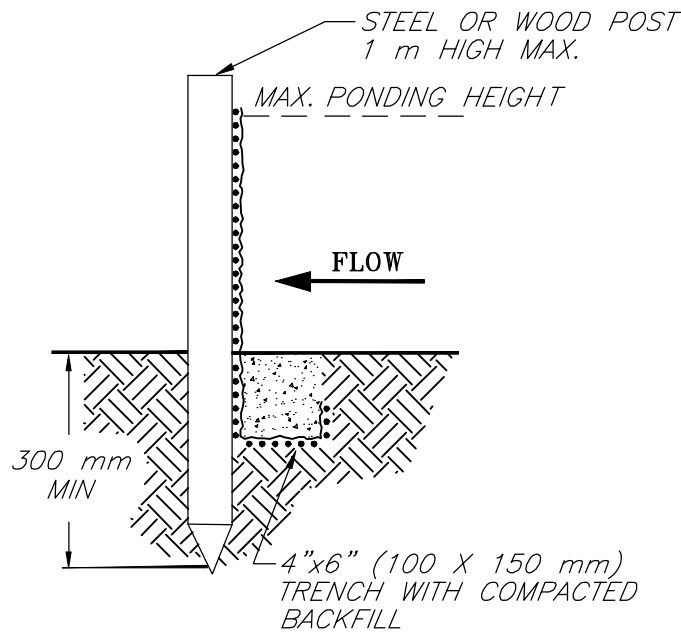
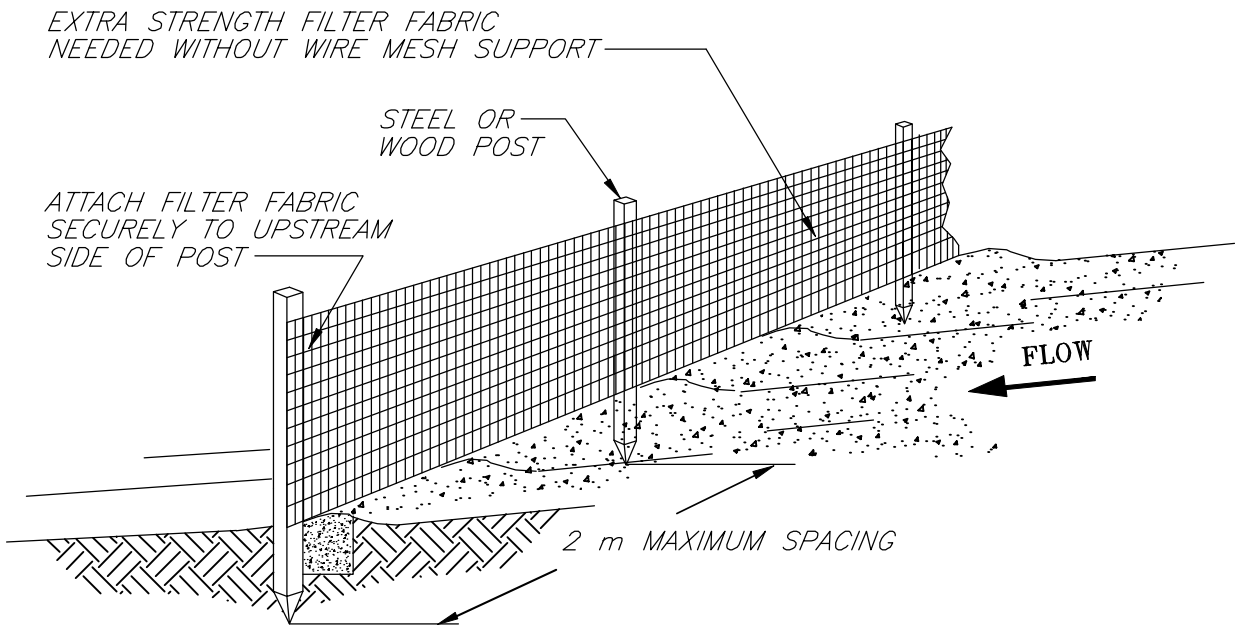

**TRENCH METHOD DETAIL**

**NOTES:**

1. SILT FENCE SHALL BE PLACED ON SLOPE CONTOURS TO MAXIMIZE PONDING EFFICIENCY.
2. INSPECT AND REPAIR FENCE DAILY AND AFTER EACH STORM EVENT AND REMOVE SEDIMENT WHEN ACCUMULATED SILT REACHES 200 mm.
3. REMOVED SEDIMENT SHALL BE DEPOSITED TO AN AREA WILL NOT CONTRIBUTE SEDIMENT OFF-SITE.
4. THIS FIGURE IS PROVIDED FOR GUIDANCE ONLY AND DOES NOT CONSTITUTE A DESIGN. A SITE SPECIFIC DESIGN IS REQUIRED FROM DESIGNER/ENGINEER.

NOT TO SCALE

**SILT FENCE**  
**(TRENCH METHOD)**

FILE: SILTFENC

© 1994 JOHN McCULLAH  
From: Salix—Applied Earthcare — EROSION DRAW 3.0



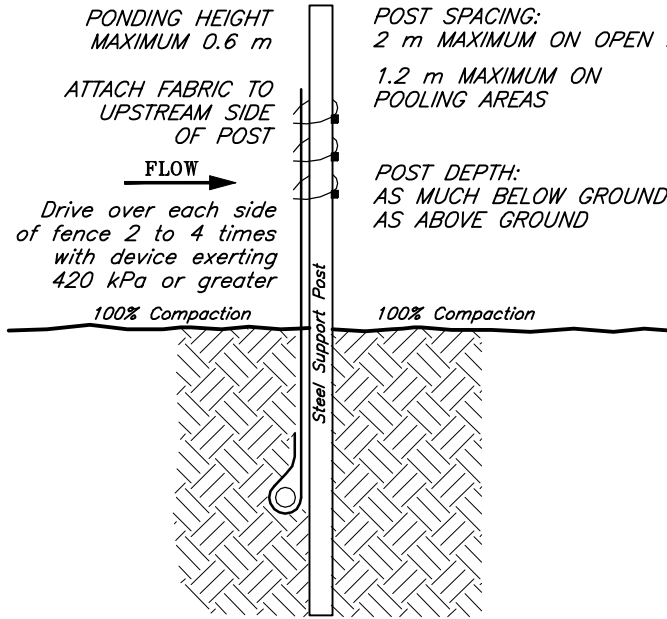

POST SPACING:  
2 m MAXIMUM ON OPEN RUNS  
1.2 m MAXIMUM ON  
POOLING AREAS

POST DEPTH:  
AS MUCH BELOW GROUND  
AS ABOVE GROUND

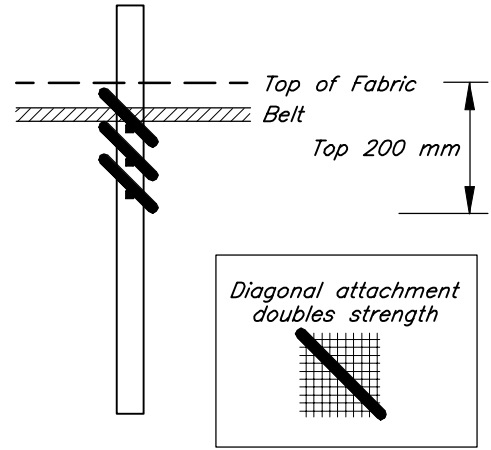

**ATTACHMENT DETAILS:**

- Gather fabric at posts, if needed.
- Utilize three ties per post, all within top 200 mm of fabric.
- Position each tie diagonally, puncturing holes vertically a minimum of 25 mm apart.
- Hang each tie on a post nipple and tighten securely.
- Use cable ties (50 lbs) or soft wire.

NO MORE THAN 0.6 m OF A 0.9 m FABRIC IS ALLOWED ABOVE GROUND

**MECHANICAL (SLICING) METHOD**

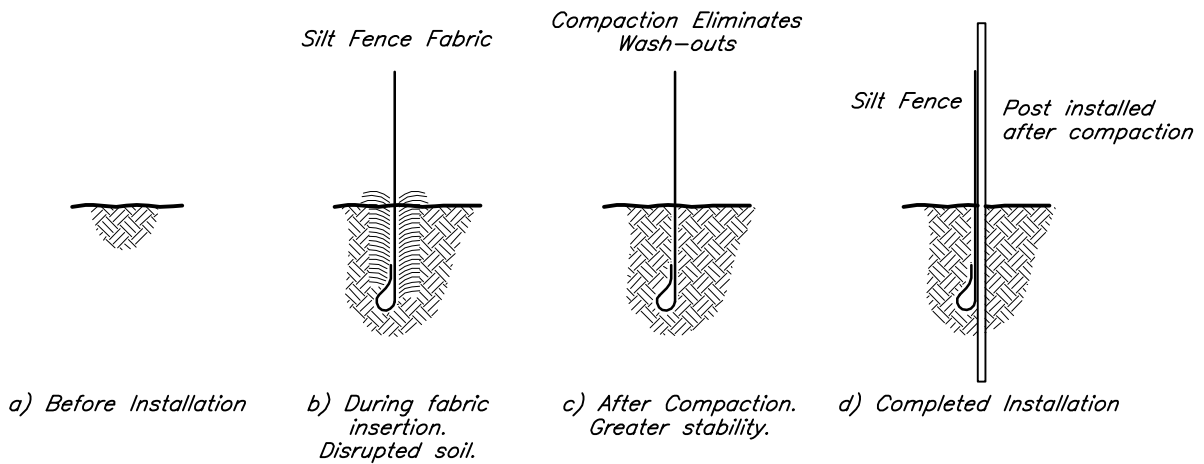

**MECHANICAL (SLICING) METHOD INSTALLATION SEQUENCE**

**NOTES:**

1. INSTALLATION MACHINE MUST ALLOW CONTINUOUS SLICING AND EMBEDMENT OF GEOTEXTILE INTO GROUND WITH MINOR GROUND DISTURBANCE.
2. INSTALLATION MACHINE TYPES WILL VARY WITH MANUFACTURER.
3. THIS FIGURE IS PROVIDED FOR GUIDANCE ONLY AND DOES NOT CONSTITUTE A DESIGN. A SITE SPECIFIC DESIGN IS REQUIRED FROM DESIGNER/ENGINEER.

*NOT TO SCALE*

**SILT FENCE**  
(MECHANICAL METHOD)

SOURCE: CARPENTER T. 2000

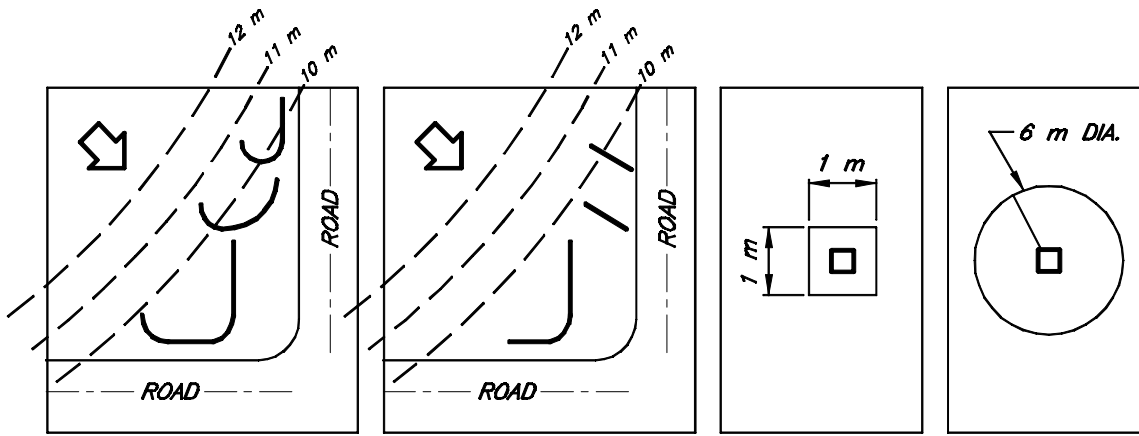

CORRECT

INCORRECT

"J" CONFIGURATION

SILT FENCE BARRIER AT STORM INLET

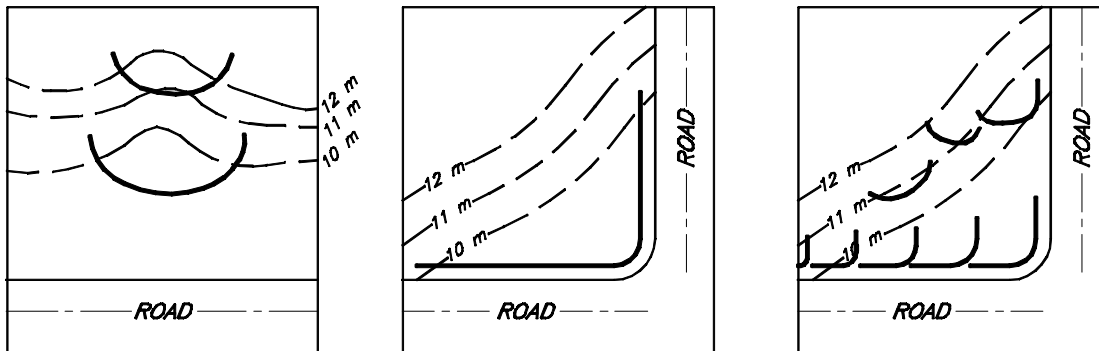

"SMILE" CONFIGURATION

AVOID LONG INSTALLATION

COMBINATION OF "SMILE" AND "J" CONFIGURATIONS

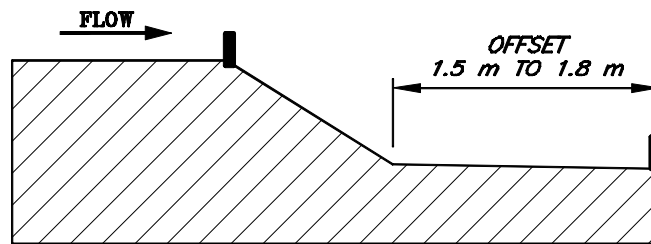

LOCATION AT TOP AND BOTTOM OF SLOPE

NOT TO SCALE

**NOTE:**

1. THIS FIGURE IS PROVIDED FOR GUIDANCE ONLY AND DOES NOT CONSTITUTE A DESIGN. A SITE SPECIFIC DESIGN IS REQUIRED FROM DESIGNER/ENGINEER.

SOURCE: CARPENTER T. 2000

**SILT FENCE  
(CONFIGURATION PLAN)**

<p>Gabions (a - c)</p> <p>Erosion Control and Sediment Control</p>	<p>B.M.P. #2 (a-c)</p>
--	----------------------------

### Description and Purpose

- Consist of rock placed inside wire baskets to protect steep or erodible slopes from sheet flow erosion
  - Protects erodible stream channel banks from potentially high erosive concentrated flow velocities or high tractive forces
- a) Slope and Banks
  - b) Single Gabion Drop Structure for Ditch Channel
  - c) Double Gabion "Energy Dissipator" Drop Structure for Ditch Channel

### Applications

- Permanent measure
- May be used on stream bank aprons and blankets where flow velocities do not exceed 6 m/s
- May be constructed to 0.5H:1V as a low height slope toe protection structure
- May be used on slopes up to 1.5H:1V as slope protection, a grade break and flow check
- Gabion matting is an alternative to riprap armouring of channels
- May be used to construct dikes or weirs
- Used as a drop structure (check structure) to reduce grade between structures and as flow check in channels
- Used as a splash pad to slow down flow velocity and dissipate flow energy

### Advantages

- Relatively maintenance free
- Long lasting and sturdy structure
- Lower thickness requirement for gabion (can be 1/2 to 1/3 riprap thickness) compared with riprap thickness for identical severe hydraulic conditions.
- Allows smaller diameter rock material to be used where it would normally be erodible with riprap placement
- Gabions are porous, free-draining and flexible so they are less affected by frost heaving and hydrostatic pressures

## Gabions (a - c)

### Erosion Control and Sediment Control

B.M.P. #2  
(a-c)

- Trap sediment and support plant growth to effect higher channel resistance to flow; however, cumulative build-up of silt may render gabions less effective with diminished height

#### Limitations

- Construction is labour intensive
- Extra costs associated with wire for mesh cages and rock fill plus geotextile fabric or sand filter layer

#### Construction

- Prepare subgrade at designated gabion location on mineral soil
- Excavate trench a minimum of 0.15 m deep to 'key-in' gabion structure
- Construct gabion basket as per manufacturer's recommendations
- Line interior of basket with non-woven geotextile OR a gravelly sand filter layer (if required by design) along areas where the basket is in contact with soil
  - Geotextile must be non-woven fabric to act as a separator (filter) between rock-infill and subgrade soils to minimize infiltration of fine grained particles into the gabion structure
- Backfill basket with rock with wire bracing at 1/3 points (or 0.3 m spacings)
- Install gabion basket top
- Backfill trench and compact soil around edges of completed basket

#### Construction Considerations

- Gabions should be placed on a properly graded surface
- Non-woven geotextile should be used to prevent loss of underlying material and infiltration of fine grained particles into the gabion structure
- Rock in the baskets may be placed by hand to enhance dense packing of stones and decrease void spaces
- Construct gabions with internal wire diaphragms to maintain structural stability and shape

#### Inspection and Maintenance

- Inspection frequency should be in accordance with the PESC and TESC Plans and should be inspected after major storm events, especially where undermining at the toe of the gabion is a concern

Gabions (a - c) Erosion Control and Sediment Control	B.M.P. #2 (a-c)
---	--------------------

- Repair as necessary; repair may include hand grading and/or infilling undermined area with rocky material
- Removal of silt should be determined based on depth of siltation, channel erosion and establishment of vegetation

#### **Similar Measures**

- Berms/Barriers
- Check Dams
- Permeable/Synthetic Barriers
- Rock/Brush barriers
- Sand/Gravel Bag Barriers

#### **Design Considerations**

- The design should include an energy dissipator (i.e., a gabion mat as a splash pad) at toe of downstream side of gabion drop structure if overtopping of the gabion is anticipated

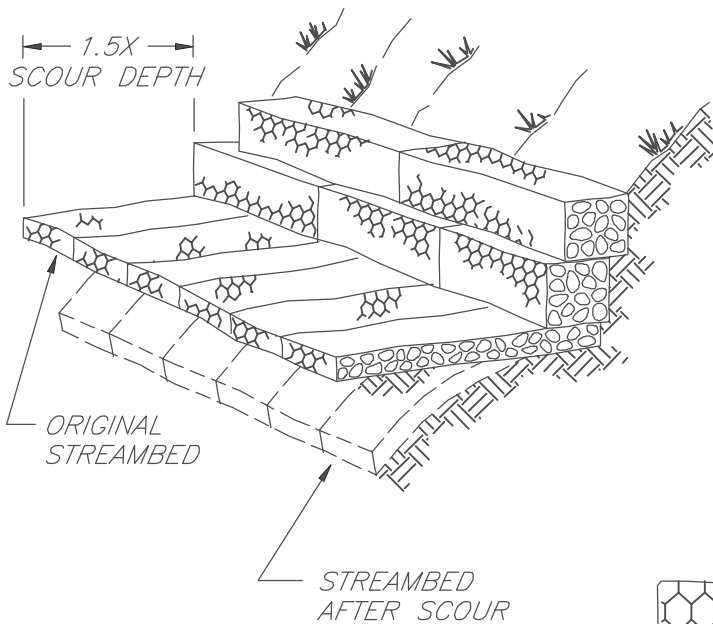

TYPICAL GABION APRON

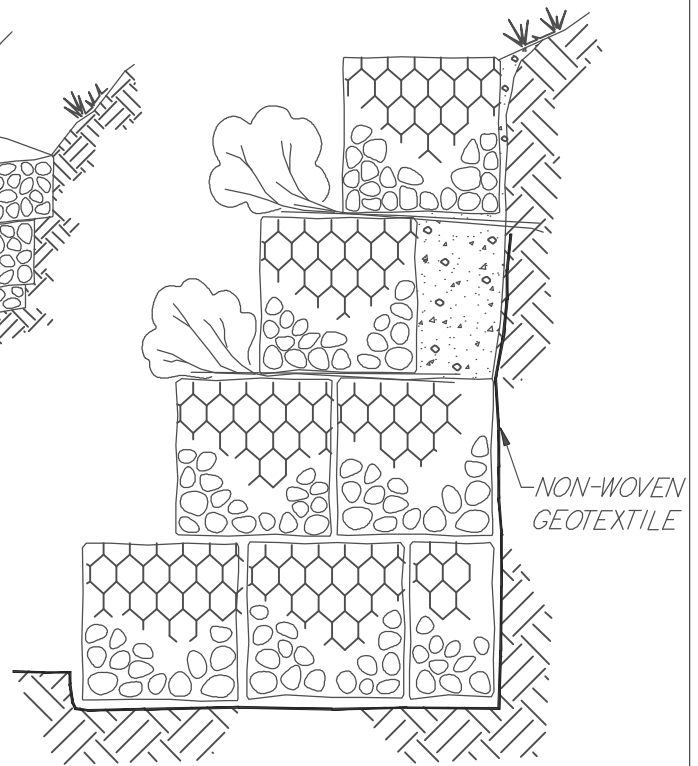

TYPICAL VEGETATED ROCK GABION

TYPICAL GABION AND GABION MATTRESS

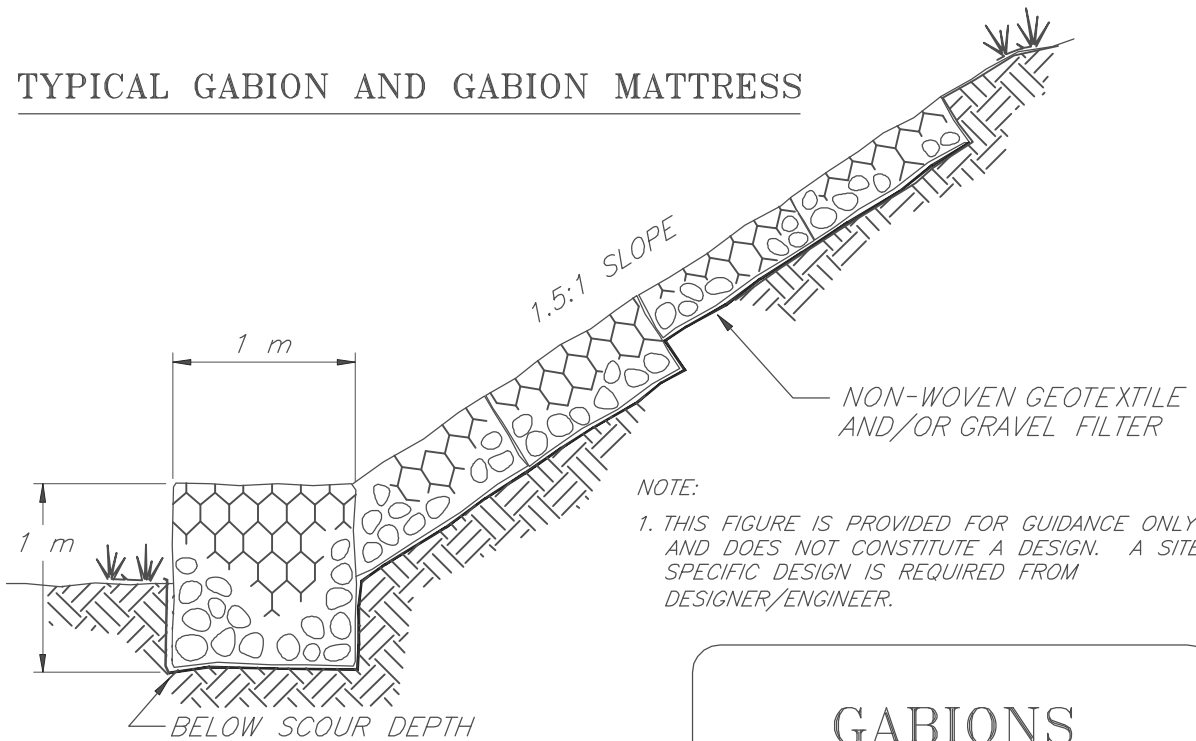

NOTE:

1. THIS FIGURE IS PROVIDED FOR GUIDANCE ONLY AND DOES NOT CONSTITUTE A DESIGN. A SITE SPECIFIC DESIGN IS REQUIRED FROM DESIGNER/ENGINEER.

**GABIONS  
(SLOPE AND BANK)**

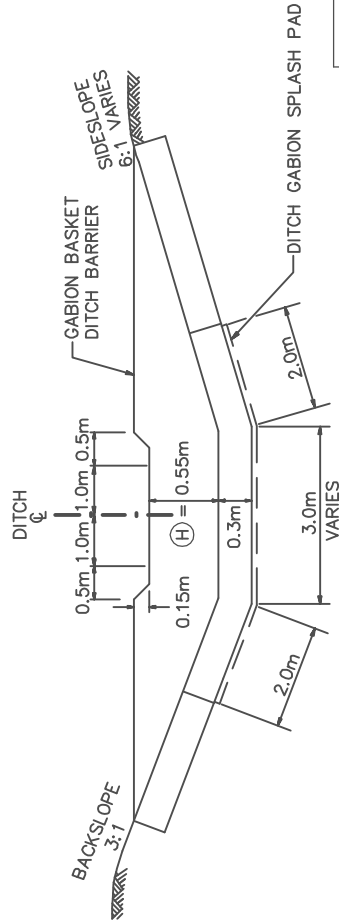

FRONT VIEW FROM DOWNSTREAM  
TYPICAL DITCH CROSS-SECTION  
GABION BASKET DITCH BARRIER

N.T.S.

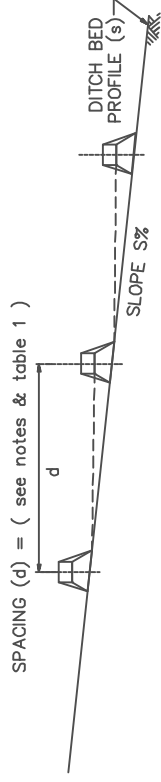

TYPICAL BARRIER SPACING

N.T.S.

SUGGESTED SPACING (d)		REMARKS
S (%)	(m)	
5-7	30	OPTION TO INSTALL A GRADE BREAK (S.A. WEAVE BARRIER) BETWEEN STRUCTURES.
7-8	25	A DOUBLE GABION FOLLOWS EVERY 2 SINGLE GABIONS.
>8%	≤15	DESIGN BY ENGINEER REQUIRED.

TABLE 1

NOTES:

- SUITABLE FOR MEDIUM TO STEEP GRADES AND CHANNELS LEADING TO WATER COURSE  $4\% < S < 10\%$ .
- SPACING TO BE DETERMINED BY ENGINEER BASED ON HYDRAULIC CONDITIONS.
  - ii) USE IN CONJUNCTION WITH DOUBLE GABIONS OR OTHER BARRIER STRUCTURES.
- SOIL COVERING BETWEEN STRUCTURES SUGGESTED FOR STEEP GRADE SOIL DITCH.
- THIS FIGURE IS PROVIDED FOR GUIDANCE ONLY AND DOES NOT CONSTITUTE A DESIGN. A SITE SPECIFIC DESIGN IS REQUIRED FROM DESIGNER/ENGINEER.

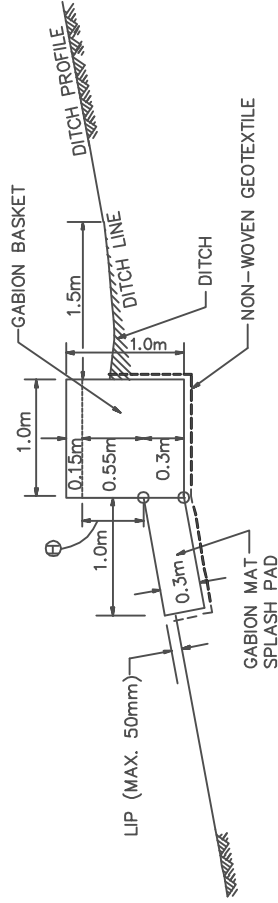

CROSS-SECTION VIEW  
"SINGLE GABION" BASKET DITCH BARRIER  
& GABION MAT SPLASH PAD

N.T.S.

GABIONS  
SINGLE GABION  
DROP STRUCTURE FOR  
DITCH CHANNEL

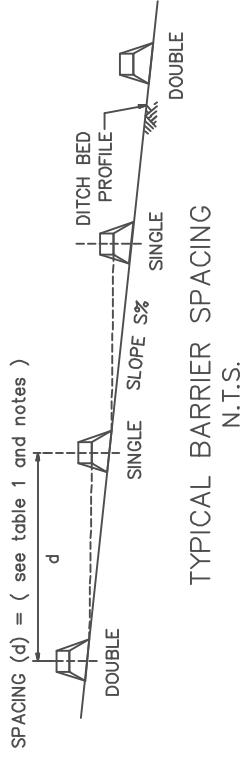

SUGGESTED SPACING (d)		REMARKS
S (%)	(m)	
6-8	25	INTER-SPACED WITH 2 SINGLE GABIONS BETWEEN STRUCTURES
>8%	35*	*SEE NOTES
>8%	≤15	DESIGN BY ENGINEER REQUIRED

TABLE 1

NOTES:

- SUITABLE FOR STEEP GRADES (6% < S < 12%) AND CHANNELS LEADING TO WATER COURSE
- i) SPACING (d) TO BE DETERMINED BY ENGINEER BASED ON HYDRAULIC CONDITIONS.  
ii) USE IN CONJUNCTION WITH SINGLE GABION AND/OR OTHER GRADE BREAK STRUCTURES.
- SUGGESTED TWO SINGLE GABIONS AT INTERVAL BETWEEN DOUBLE GABIONS.
- SOIL COVERING BETWEEN STRUCTURES SUGGESTED FOR STEEP GRADE SOIL DITCH.
- IF d\* = 35 m at 7 to 8% GRADE
  - GRADE BREAK (s.a. PERMEABLE WEAVE BARRIER) SHOULD BE PLACED BETWEEN STRUCTURES.
  - LONG SPACING ALLOWABLE WHEN HYDRAULIC CONDITIONS NOT SEVERE.
- THIS FIGURE IS PROVIDED FOR GUIDANCE ONLY AND DOES NOT CONSTITUTE A DESIGN. A SITE SPECIFIC DESIGN IS REQUIRED FROM DESIGNER/ENGINEER.

**GABIONS**  
**DOUBLE GABION**  
**"ENERGY DISSIPATOR"**  
**DROP STRUCTURE**  
**FOR DITCH CHANNEL**

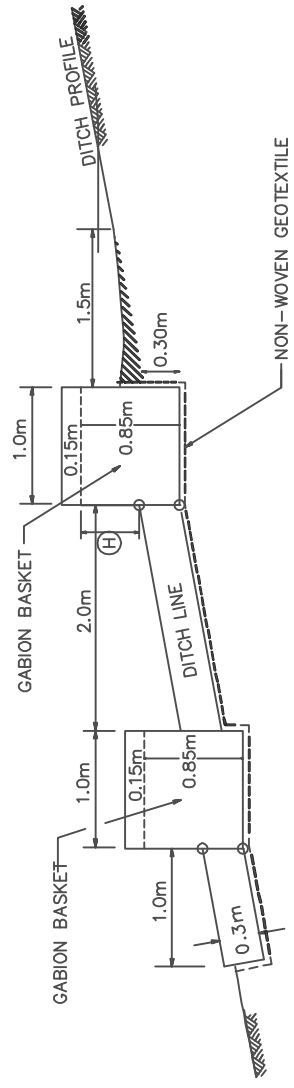
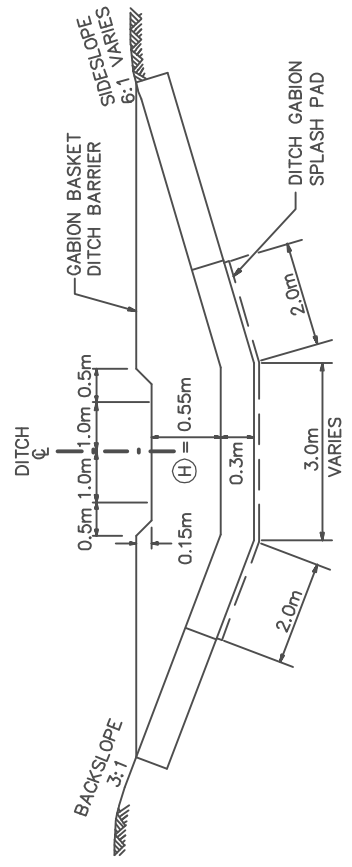

### **Description and Purpose**

- Constructed of sand or gravel-filled geotextile, or formed structures comprised of compost, shredded wood mulch, and natural fibres
- Used to divert and intercept sheet or overland flow
- May be used to form ponds and allow sediment to settle out
- Compost should possess no objectionable odours or substances toxic to plants
- Compost contains plant nutrients but is typically not characterized as a fertilizer

### **Applications**

- Temporary measure
- May be used in place of silt fences or straw bale barriers to retain sediment on construction sites
- Compost used on AT projects must meet Canadian Council of Ministers of the Environment (CCME) Guidelines for Compost Quality (trace elements, maturity/stability, pathogens), which are adopted by Alberta Transportation and found on AT Products List ([www.transportation.alberta.ca](http://www.transportation.alberta.ca)).
- May be used in place of silt fences or straw bale barriers to retain sediment on construction sites

### **Advantages**

- Trenching may not be required as weight and flexibility of structure typically allows continuous contact with ground surface

### **Limitations**

- Sand or gravel filled geotextile requires Continuous Structure Machine (CBM) for construction
- Requires specialized blower truck, hose and attachments for berm installation

### **Construction**

- Install structure a minimum of 2 m away from toe of slope to provide adequate ponding area on upstream side of structure
- Follow operating procedures for CBM
- Use of woven geotextile is preferred due to higher tensile strength and small deformation

# Continuous Perimeter Control Structures

## Sediment Control

B.M.P. #4

- If required, PVC drainage pipes (e.g., 50 mm) may be inserted in downstream side of structure, spaced 100 to 150 mm apart, to facilitate drainage
- If required and appropriate, slits may be cut in upstream side of structure to facilitate filtering and drainage

### *Compost filter berm installation:*

- Parallel to the base of the slope, or around the perimeter of affected areas, construct a trapezoidal berm at the following dimensions:

Annual Rainfall/Flow Rate	Total Precipitation	Berm Dimensions (height x width)
Low	25 mm – 635 mm	30 cm x 60 cm – 45 cm x 90 cm
Average	635 mm – 1270 mm	30 cm x 60 cm – 45 cm x 90 cm
High	>1270 mm	45 cm x 90 cm – 60 cm x 120 cm

- Base of berm is twice the height
- Compost shall be uniformly applied using an approved spreader unit - including pneumatic blowers, specialized berm machines, etc
- Seeding the berm may be done in conjunction with pneumatic blowing
- Compost can be blown into a netted sock to be used as a berm

### **Construction Considerations**

- Structure constructed of sand, aggregate, or other pervious soil encased in geotextile fabric
- Maximum structure height is approximately 0.4 m
- Higher permeability fill materials should be used in 'drainage chambers' in low areas
- Compost filter berm dimensions and blanket application rates vary with soil characteristics, existing vegetation and climatic conditions
- Use larger berm application rate in high rates of precipitation and rainfall intensity, and snow melt
- Use larger berms in severe grade and long slope lengths
- Berms may be placed at the top and the base of a slope
- A series of berms may be used down a slope (5 to 8 m apart)
- Berms may be used in conjunction with a compost blanket, especially in regions with spring melt, and sites with severe grades and long slopes

## Continuous Perimeter Control Structures

### Sediment Control

B.M.P. #4

- Use smaller berm application rate in lower precipitation rates and rainfall intensity regions
- Use larger berms where they are required to be in place or function for more than one year

#### **Inspection and Maintenance**

- Inspection frequency should be in accordance with PESC and TESC Plans.
- Inspect for sediment accumulation and remove sediment when depths reach approximately one-third the structure height
- Inspect for toe undermining, weathered/deteriorated geotextile, and end runs and erosion of the filter and repair immediately
  - Damaged sections may be repaired by restapling or placing another section of continuous structure upstream of the damaged section to provide seal
- If the structure is encased in a geotextile fabric, removal of structure is accomplished by splitting the structure, spilling fill material and removing fabric
- Removal of berm is accomplished by splitting the berm and sock, spilling fill material and removing sock

#### **Similar Measures**

- Structures/Barriers
- Sand/Gravel Bag Barriers
- Silt Fence
- Compost Berm

Berm Interceptor Sediment Control	B.M.P. #5
--------------------------------------	-----------

### **Description and Purpose**

- Earth dyke barrier constructed of compacted soil to intercept and divert flow of runoff water away from erodible slopes, sensitive areas or water bodies
- A spillway outlet of erosion-resistant granular material constructed to allow exit of diverted water to less sensitive areas

### **Applications**

- Temporary or permanent measure
- Used instead of, or in conjunction with, diversion ditches
- Perimeter control
- Placed along contours and/or at toe of slope to divert run-off from sensitive areas
- Used to divert water to sediment control structures

### **Advantages**

- Easy to construct
- Can be converted to sedimentation/impoundment pond with the design of a permeable filter berm at the exit spillway area (see BMP #13)

### **Limitations**

- Generally, earth dyke barriers can be 1 to 2 m in height. Design by a geotechnical engineer is required for barriers greater than 3 m in height in accordance with dam design guidelines and regulatory requirements. The consequences of failure will influence the level of design and construction requirements

### **Construction**

- Construct barrier from bottom up by placing and compacting subsequent lifts of soil
- Degree of compaction of each lift to be specified by the design engineer based on consequences of failure

Berm Interceptor	B.M.P. #5
Sediment Control	

### **Construction Considerations**

- The barrier should be trapezoidal in cross-section
- Low barriers should have the slopes suited to the construction material used
  - 1.5H:1V for granular soils
  - 2H:1V or flatter for compacted mixed or fine grained soils
    - Slope should be flattened to a minimum of 3H:1V for uncompacted fine grained soils

### **Inspection and Maintenance**

- The degree and extent of inspection and maintenance performed on a earth dyke barrier is directly related to the consequences of failure. An engineer experienced in embankment design and inspection may be required for design, inspection, design of remedial measures, and supervision of their implementation
- Inspection frequency should be in accordance with the PESC and TESC Plans
- Piping failures may be remedied by replacing saturated soils with drier compacted soil and/or by placement of geotextile over the failed area and placing a stabilizing toe berm constructed of granular materials
- Inspect for sediment accumulation and remove sediment when depths reach approximately one-half the barrier height
- Deactivate and remove barrier once slope soils have stabilized and return barrier location to an acceptable condition

### **Similar Measures**

- Berms
- Sand/Gravel Bag Barriers

### **Design Considerations**

- Geotechnical design required for barriers constructed of fine grained soils and greater than 3 m in height

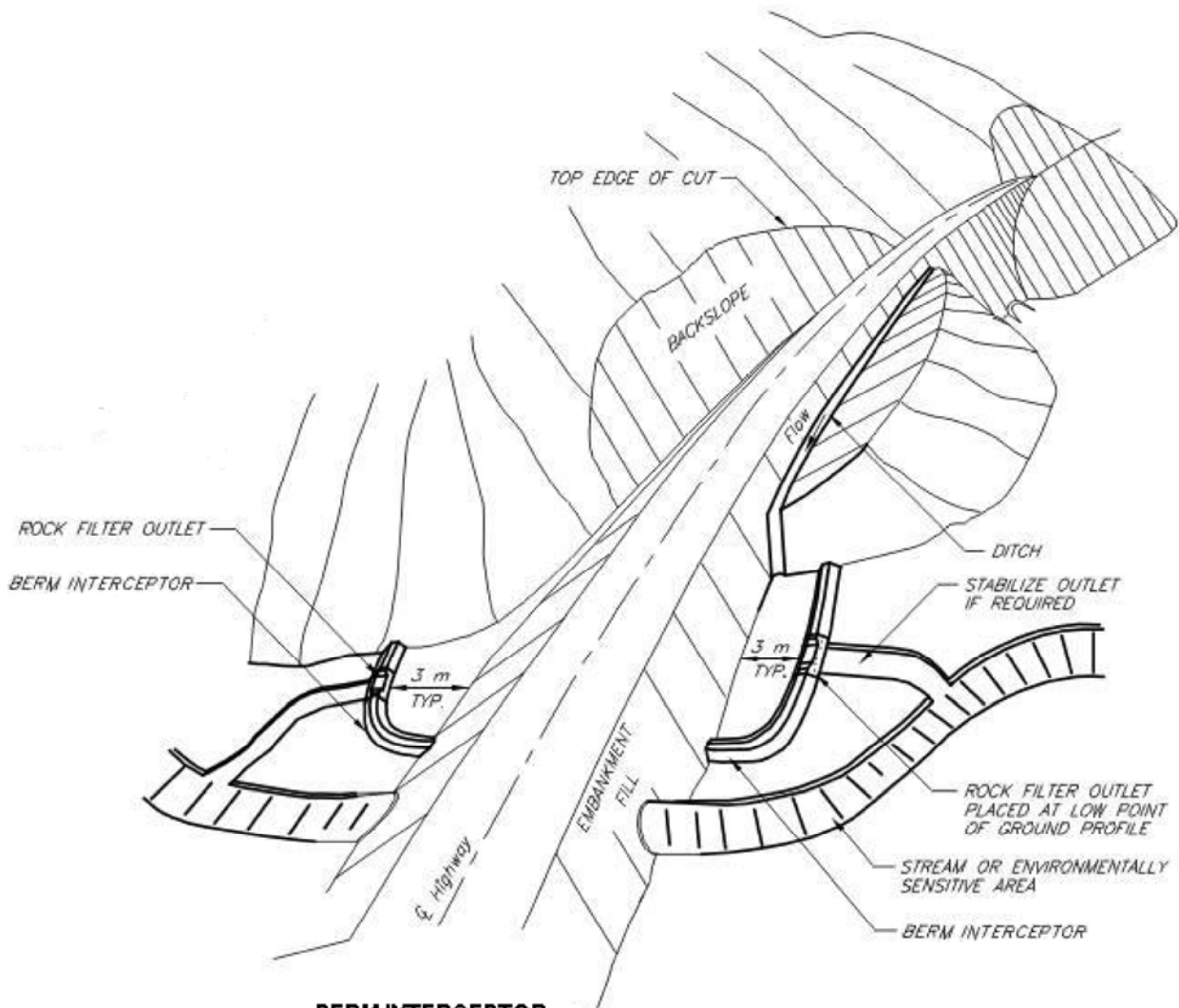

**BERM INTERCEPTOR**  
**TYPICAL LOCATION**

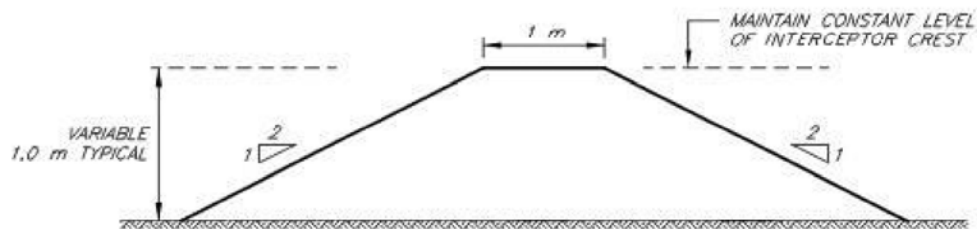

**TYPICAL SECTION**  
**BERM INTERCEPTOR**

**NOTES:**

1. SILT ACCUMULATION TO BE REMOVED WHEN HALF BERM INTERCEPTOR HEIGHT COVERED.
2. THIS FIGURE IS PROVIDED FOR GUIDANCE ONLY AND DOES NOT CONSTITUTE A DESIGN. A SITE SPECIFIC DESIGN IS REQUIRED FROM DESIGNER/ENGINEER.

**BERM  
INTERCEPTOR**

**Description and Purpose**

- Small dam constructed of rock placed across steep channel
- Decrease flow velocities to reduce erosion caused by storm runoff
- Sediment laden runoff is detained allowing sediment to settle out

**Applications**

- Temporary or permanent measure
- Reduces long steep grade to intervals of gentle grades between successive structures
- Reduces flow velocities and kinetic energy to decrease erosion potential caused by runoff
- Sediment laden runoff is retained behind structure allowing sediment to settle out
- May be used in channels that drain 4 ha (10 ac) or less
- May be used in steep channels where storm water runoff velocity is less than 1.5 m/s (5 fps)

**Advantages**

- Cheaper than using riprap armouring or gabion structures in a ditch
- Easy to construct

**Limitations**

- Not appropriate for high flow velocity >1.5 m/sec; (use gabion structures for flow velocity >1.5 m/sec)
- Not appropriate for channels draining areas larger than 4 ha (10 ac)
- Not to be placed in grass lined channels unless erosion is anticipated
- Susceptible to failure if water undermines or outflanks structure

**Construction**

- Excavate a trench key a minimum of 0.15 m in depth at the rock check structure location
- Place non-woven geotextile fabric over footprint area of rock check
- Construct structure by machine or hand
- Structure should extend from one side of the ditch or channel to the other

- Structure should be constructed so that centre of the crest is depressed to form a centre flow width which is a minimum of 0.30 m lower than the outer edges
- Height of structures should be less than 0.8 m in height to avoid impounding large volumes of runoff
- Downstream slope of the check dam should be 5H:1V (minimum)
- Upstream slope of the check dam should be 4H:1V (minimum)

### Construction Considerations

- Should be designed with roadside design clear zone requirements in mind.
- Height and spacing between structures should be designed to reduce steep channel slope to intervals of flatter gradient
- Rock check structures should be constructed of free draining aggregate
- Aggregate used should have a mean diameter ( $D_{50}$ ) of between 75 mm and 150 mm and must be large enough to remain in place during high velocity flow situations. Maximum rock diameter should not exceed 150 mm if the structure is to be used as a sediment trap.
- If rock check structures are to be placed in channels with significant high flows, they must be properly designed for stone size and structure spacings

### Inspection and Maintenance

- Inspection frequency should be in accordance with the PESC and TESC Plans
- Remove sediment build up before it reaches one half the check structure height
- Erosion repairs should be made immediately to prevent failure of the structure
- Replace dislodged aggregate immediately with heavier aggregate or gabion structures

### Similar Measures

- Synthetic Permeable (Ditch) Barriers

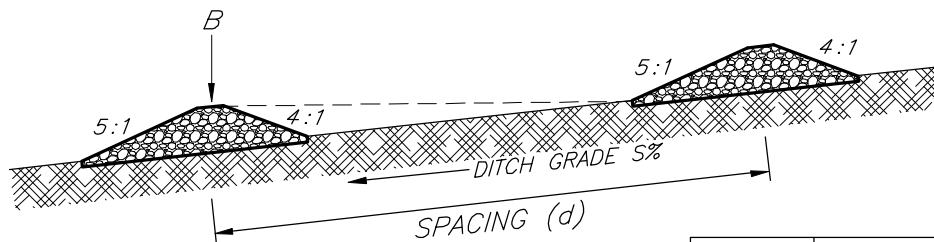
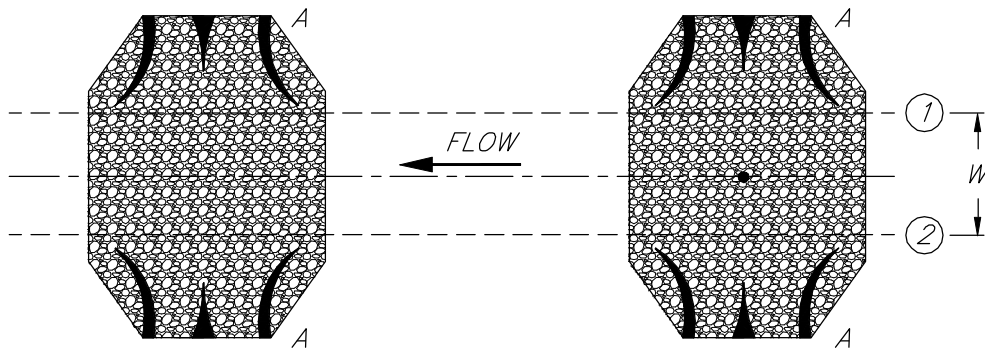
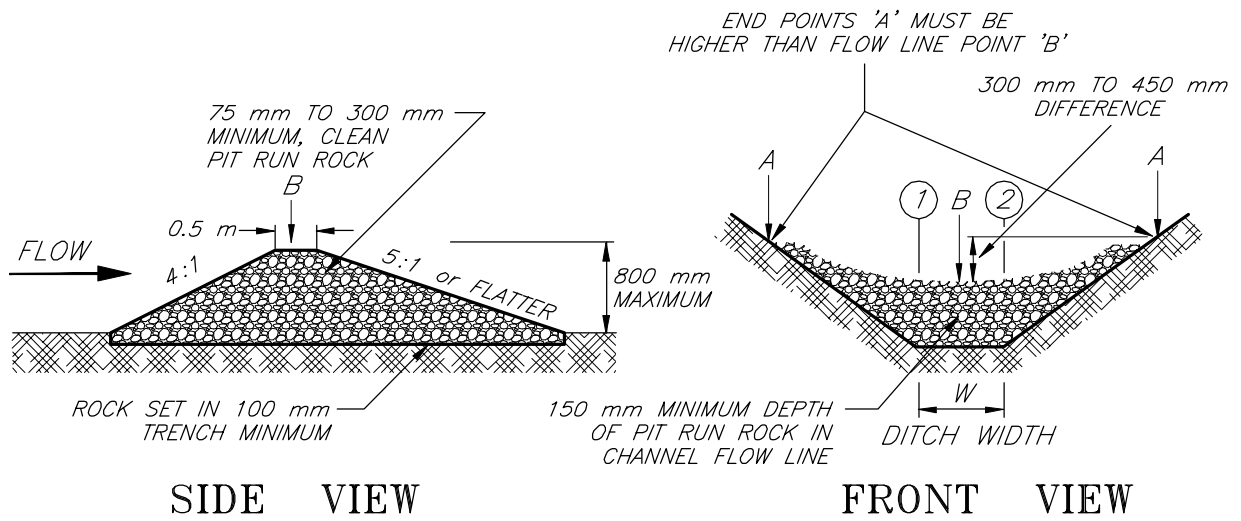

**NOTES:**

1. SUITABLE FOR FLOW VELOCITY  $\leq 1.5$  m/s.
2. SUITABLE FOR DRAINAGE AREA  $\leq 4$  ha.
3. SUITABLE FOR GRADES FROM 5% TO 8%.
4. SPACING (d) AND ROCK SIZE ( $D_{50}$ ) TO BE DETERMINED BY ENGINEER BASED ON HYDRAULIC CONDITIONS.
5. THIS FIGURE IS PROVIDED FOR GUIDANCE ONLY AND DOES NOT CONSTITUTE A DESIGN. A SITE SPECIFIC DESIGN IS REQUIRED FROM DESIGNER/ENGINEER.

$D_{50}$ of ROCK ( mm )	MAXIMUM FLOW DEPTH OVER ROCK ( mm )
75	50
150	100

**SUGGESTED ROCK DIAMETER AND OVERFLOW DEPTHS**

**ROCK CHECK DAM**

NOT TO SCALE

### **Description and Purpose**

- Double panel, low profile, uni-body porous synthetic barriers used to dissipate flow energy and reduce velocity
- Barriers of patented design constructed of lightweight and durable synthetic materials
- May be used to create a grade break to reduce flow energy and velocities allowing some sediment to settle out at the upstream barrier panel of the barrier structure
- Can be used to dissipate flow energy and trap sediment during the period of revegetation; should be removed at successful re-establishment of vegetation

### **Applications**

- Temporary structure
- May be placed across trapezoidal ditch to dissipate flow energy and reduce flow velocities
- Can be used to supplement as grade breaks along ditch interval between permanent drop structures along steep ditch grades
- May be used as midslope grade breaks along contours of midslope or at toe of disturbed slopes
- Usually used as grade breaks along ditch (3 to 7% grade) in conjunction with erosion control matting or non-woven geotextile as soil covering mattings; usually used in conjunction with permanent gabion structure (i.e., gabion) at steep grade (+6%) areas
- Designed to be reusable

### **Advantages**

- Prefabricated
- Reusable/moveable
- More appropriate for installing at transition areas of changing grades of channels so that hydraulic jumps (or change of flow regime from supercritical to subcritical) may be simulated to dissipate flow energy, thus minimizing erosion potential
- Provide portable drainage control for construction sites, ditches, channels, roads, slopes
- The double panel porous barrier may allow significant energy loss as the flow of water undergoes from supercritical flow to sub-critical flow from the upstream panel

# Synthetic Permeable Barrier

## Erosion Control and Sediment Control

B.M.P. #10

to the downstream panel with a more laminar flow evolving downstream and roughly parallel to the stream bed. Less turbulence and erosion energy may be created when compared with cascading, over-topping and tumbling flow from drop structures (i.e., gabions, check structures, straw bales)

- Barriers constructed of UV resistant material may be left in place for final channel stabilization as UV degradation is low
- Biodegradable synthetic option available
- Observed to enhance aggregation of silt material and to function as a sediment barrier with the formation of an earth block at behind the upstream barrier panel area; the downstream flow exiting at the downstream barrier panel may be of laminar nature and less erosive

### Limitations

- More appropriate for use as a grade break and may be installed between permanent drop structures
- Partially effective in retaining some sediment and reducing flow velocities
- Less sturdy as drop structures in resisting high flow impact
- Not to be designed as drop structures
- Must be hand installed
- Become brittle in winter and may be easily damaged by highway maintenance activities or by public
- At the time of deactivation of the structure after vegetation establishment, metallic anchor pins, if not biodegradable, may require removal at time of completed revegetation
- Stick-up of metallic anchor pin above ground may be a nuisance and may be a human hazard and cause damage to maintenance equipment
- The use of biodegradable anchor pins is advisable

### Construction

- Install as per manufacturers recommended installation instructions
- Normally installed in conjunction with erosion control matting in ditches and channels
- Prepare soil surface
- Install basal layer of erosion mat or geotextile fabric; key-in basal mat/fabric at upstream end

## Synthetic Permeable Barrier

### Erosion Control and Sediment Control

B.M.P. #10

- Place and anchor barrier panels with adequate pin anchors to basal soils

#### **Construction Considerations**

- Maintain intimate contact between base of barrier and soil with laying of basal matting/fabric intimate to ground surface
- Ensure side panel of barrier is extended to outer edges of channel to sufficient height to provide freeboard of channel flow

#### **Inspection and Maintenance**

- Inspection frequency should be in accordance with the PESC and TESC Plans
- Remove sediment build-up before it reaches one-half the check structure height
- Do not damage barrier panel during removal of sediment
- Partial or non-removal of sediment build-up will create a non-permeable barrier and low level earth mini-drop structure which will force water flow over-topping the barrier. The option of non-removal of sediments may be open to converting the sediment build-up into a "vegetated earth mini-drop structure" along the ditch with the non-removal of synthetic permeable barrier in-place. This will require topsoil and seeding (or intensive mulch seeding) to promote vegetation growth
- If erosion is noted at the toe or upslope edges of the structure, hand regrading or suitable repairs should be made immediately to prevent failure of the structure
- Remove and deactivate at 1 year after vegetation is established

#### **Similar Measures**

- Silt fences or straw bales partially equivalent in retaining sediment

#### **Design Considerations**

- Install synthetic permeable barrier along ditch interval between permanent drop structures (i.e., gabion); can be economic alternative and supplemental to (i) total hard armouring of complete channel length, or (ii) high frequency of gabion installation required for high flow applications in steep ditch grade

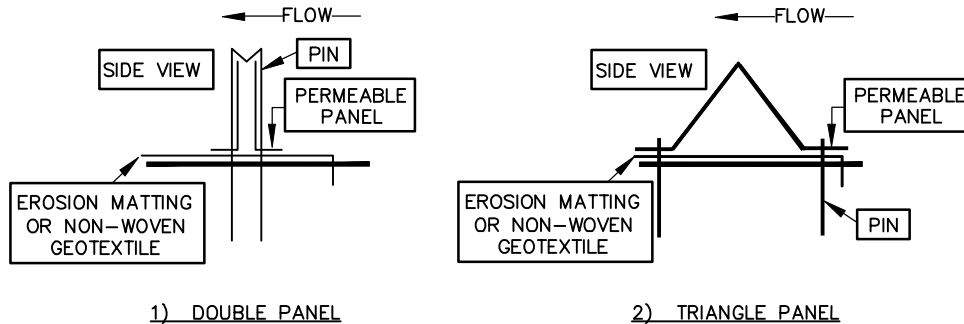
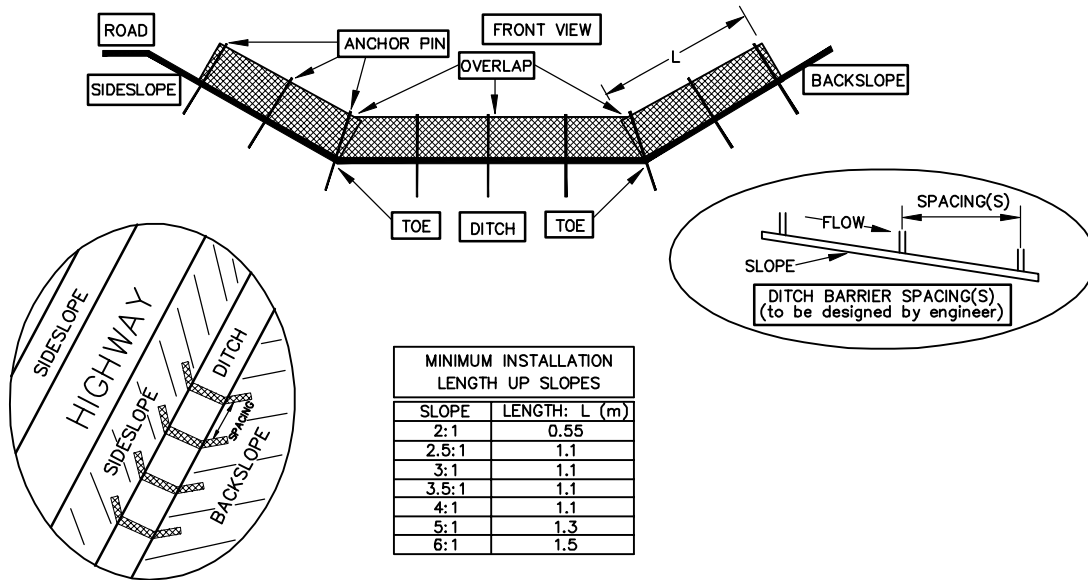

SYNTHETIC PERMEABLE DITCH BARRIER  
N.T.S.

NOTES:

1. FOR USE MAINLY AS A GRADE BREAK STRUCTURE FUNCTIONING AS A FLOW ENERGY DISSIPATOR AND VELOCITY RETARDER.
2. FOR SECONDARY USE AS SEDIMENT BARRIER.
3. REQUIRES NON-WOVEN GEOTEXTILE FABRIC OR BIODEGRADABLE (COCONUT FIBRE PREFERABLE) EROSION BLANKET MAT AT BASE AND KEY-IN TO SOIL AT UPSTREAM END.
4. MAY BE INSTALLED AS GRADE BREAK AT GRADE TRANSITION AREAS TO CREATE DISSIPATION OF FLOW ENERGY AND A MORE LAMINAR FLOW REGIME DOWNSTREAM OF STRUCTURE.
5. THIS FIGURE IS PROVIDED FOR GUIDANCE ONLY AND DOES NOT CONSTITUTE A DESIGN. A SITE SPECIFIC DESIGN IS REQUIRED FROM DESIGNER/ENGINEER.

SYNTHETIC  
PERMEABLE  
BARRIERS

## Rolled Erosion Control Products (RECP)

- a) Channel Installation
- b) Slope Installation
- c) Straw Rolls

B.M.P. #13

## Erosion Control

### Description and Purpose

- Biodegradable or synthetic soil coverings used for temporary or permanent protection of disturbed soils at slopes and channels
- Categories of Rolled erosion control products (RECP) can be:
  - Erosion control blankets (ECB) (generally biodegradable and temporary)
  - Turf reinforcement mats (TRM)
  - Composite turf reinforcement mats (C-TRM)
- RECP may be manufactured of organic material, synthetic material, or as a composite of organic and synthetic materials
- Protect disturbed soils from raindrop impact and surface runoff erosion, increase water infiltration into soil, retains soil moisture and decreases evaporation loss
- Protect seeds from raindrop impact, runoff, and predators
- Stabilizes soil temperature to promote seed germination and enhance vegetation growth

### Applications

- Temporary or permanent measure
- May be used to protect disturbed, exposed soils for cut or fill slopes at gradients of 2.5H:1V or steeper
- May be used on slopes where erosion potential is high
  - Silts and sands have higher erosion potential than high plastic clays
- May be used on slopes where vegetation is likely to be slow to develop
- May be used to protect disturbed exposed soils in ditches and channels (with high flow velocities) by providing additional tractive resistance cover in conjunction with a successful high density vegetative growth established

### Advantages

- Degree of erosion protection is higher, more uniform, and longer lasting than for sprayed-on products (e.g., mulches)
- Wide range of commercially available temporary (biodegradable) or permanent products

## Rolled Erosion Control Products (RECP)

- a) Channel Installation
- b) Slope Installation
- c) Straw Rolls

## Erosion Control

B.M.P. #13

### Limitations

- Non-performance of RECP may result from the following:
  - Low density vegetation growth (beneath RECP) due to non-favourable weather and growth conditions (i.e., soil type, moisture, storm events at critical times). It is noted that values of tractive resistance of RECP products for vegetative growth may be generally tested in laboratory after a growth period (e.g., 3 months) under greenhouse growth conditions. The effectiveness of RECP, especially along channels, is very dependent on success of vegetation growth on site. It is important that the designer should assess the effectiveness of RECP in accordance with site, soil, terrain and vegetation growth conditions
  - Hydraulic uplift of RECP and erosion of underlying soils can occur under rapid snow melt conditions when dammed up melt water generates a hydraulic head and high flow velocity generated in constricted snow melt channel. This situation can occur along steep channels interlaced with drop structures and with RECP lining installed in-between the drop structures. Ponding of melt water and non-anchored RECP joint areas allow flow entry beneath the RECP and generate hydraulic heads to uplift the RECP. This can occur along un-anchored edges of RECP at upper edges of ditch when snow melt occurs at tops of ditch and flow beneath the RECP. This is especially critical when underlying soil is easily erodible. (e.g., fine grained non-cohesive silty soils). It is important to trench-in and anchor the edges of the RECP installations and installed anchor pin (staples) at sufficient dense intervals
  - Ice build-up from groundwater seepage source can uplift and dislocate the RECP and causing flow beneath the RECP to erode the substrate soils. Winter ice accumulation may be related to groundwater regime and investigative design on subsurface drainage by a geotechnical engineer is required
- Can be labour intensive to install
- Must be installed on unfrozen ground
- Temporary blankets may require removal before implementation of permanent measures
- Rolled erosion control products (RECP) are not suitable for rocky sites
- Proper surface preparation is required to ensure intimate contact between blanket and soil
- Plastic sheeting can be used at sensitive slopes with precautions:
  - Plastic sheeting RECP product can be easily torn, ripped, non-biodegradable, and should be disposed of in a landfill

## Rolled Erosion Control Products (RECP)

- a) Channel Installation
- b) Slope Installation
- c) Straw Rolls

### Erosion Control

B.M.P. #13

- Plastic sheeting product, if used, results in 100% runoff, thus increasing erosion potential in downslope areas receiving the increased flow volumes
- Plastic sheeting should be limited to temporary covering of sensitive soil stockpiles or temporary covering of small critical unstable slope areas

#### Construction (Slopes)

- RECP should be installed in accordance with manufacturer's directions

The following is a general installation method:

- Prepare surface and place topsoil and seed
- Surface should be smooth and free of large rocks, debris, or other deleterious materials
- Blanket should be anchored at top of slope in a minimum 0.15 m by 0.15 m trench for the entire width of the blanket
- The blanket should be rolled out downslope
  - (1) Where the blanket roll is not long enough to cover the entire length of the slope, a minimum 0.15 m by 0.15 m check slot should be excavated at the location of the lap, and the downslope segment of blanket anchored in the check slot, similar to the method used for the top of the slope, or (2) when blankets must be spliced down the slope, place blanket end over end (shingle style with approximately 0.10 m overlap. Staple through overlapped area at 0.3 m intervals.
  - The upslope portion of blanket should overlap the downslope portion of blanket, shingle style, at least 0.15 m with staple anchors placed a maximum 0.3 m apart
  - Adjacent rolls of blanket should overlap a minimum 0.1 m
  - Anchors should be placed along central portion of blanket spaced at 4/m<sup>2</sup> minimum (0.5 m spacing) for slopes steeper than 2H:1V and 1/m<sup>2</sup> (1 m spacing) for slopes flatter than 2H:1V
  - Anchors along splices between adjacent rolls should be placed 0.9 m apart

#### Construction (Channels)

- **A Blanket should be installed in accordance with manufacturers directions**

The following is a general installation method

- Prepare surface and place topsoil and seed

## Rolled Erosion Control Products (RECP)

- a) Channel Installation
- b) Slope Installation
- c) Straw Rolls

B.M.P. #13

### Erosion Control

- Surface should be smooth and free of large rocks, debris, or other deleterious materials
- Begin by excavating a minimum 0.15 m deep and 0.15 m wide trench at the upstream end of channel and place end of RECP into trench
  - Use a double row of staggered anchors approximately 0.1 m apart (i.e., 0.2 m linear spacing) to secure RECP to soil in base of trench
  - Backfill and compact soil over RECP in trench
- Roll centre RECP in direction of water flow on base of channel
- Place RECP end over end (shingle style) with a minimum 0.15 m overlap downgrade
  - Use a double row of staggered anchors approximately 0.1 m apart to secure RECP to soil
- Full length edge of RECP at top of sideslopes must be anchored in a minimum 0.15 m deep and 0.15 m wide trench
  - Use a double row of staggered staple anchors a maximum of 0.1 m apart (i.e., 0.2 m linear spacing) to secure RECP to soil in base of trench
  - Backfill and compact soil over RECP in trench
- Overlap RECP on sideslopes (shingle style down channel) a minimum of 0.1 m over the centre RECP and secure RECP to soil with anchors spaced a maximum of 0.2 m apart
- In high flow channels, a check slot across the width of the channel is recommended at a maximum spacing of 10 m to anchor the ends of the RECP to the underlying soil
  - Use a double row of staggered staple anchors a maximum of 0.1 m apart (0.2 m linear spacing) to secure RECP to soil in base of check slot
  - Backfill and compact soil over RECP in check slot
- Anchor terminal ends of RECP in a minimum 0.15 m deep and 0.15 m wide trench
  - Use a double row of staggered anchors a maximum of 0.1 m apart (i.e., 0.2 m linear spacing) to secure RECP to soil in base of trench
  - Backfill and compact soil over RECP in trench

## Rolled Erosion Control Products (RECP)

- a) Channel Installation
- b) Slope Installation
- c) Straw Rolls

## Erosion Control

B.M.P. #13

### Construction Considerations

- Slopes should be topsoiled and seeded prior to placing RECP
- Ensure blanket is in intimate contact with the soil by properly grading soil, removing rocks or deleterious materials, prior to placing blanket
- In channels, blankets should extend to above the anticipated flow height, with a minimum 0.5 m of free board
- For turf reinforcement mat (TRM), blanket should be placed immediately after topsoiling
- Blanket should be anchored by using wire staples, metal geotextile stake pins, or triangular wooden stakes
  - All anchors should be a minimum of 0.15 to 0.2 m in length
  - For loose soils, use longer anchors
- Blankets should be placed longitudinal to direction of flow, with fabric not stretched but maintaining contact with underlying soil
- It is essential to understand product specifications and follow manufacturers instructions on installation methods

### Product Quality Assurance/Quality Control (QA/QC) Certification

RECPs should be certified by the supplier/manufacturer to ensure product performance and compliance with specified property requirements. A certificate for QA/QC testing of manufactured products is required. The performance and QA/QC testing should be carried out by reputable laboratories (e.g., TxDoT – Hydraulic and Erosion Control Laboratory OR equivalent laboratory) to ensure a commonly acceptable QA/QC standard. Dependent on product type and intended performance, the product information certificate should be provided by the product supplier/manufacturer to include the following:

- Manufacturer's Certificate on
- Performance specification
  - Permissible Tractive Resistance (include testing methods and vegetative growth conditions)
  - Permissible Flow Velocity (if available)
  - Longevity (for biodegradable or non-biodegradable products)

## Rolled Erosion Control Products (RECP)

- a) Channel Installation
- b) Slope Installation
- c) Straw Rolls

B.M.P. #13

## Erosion Control

- Minimum Average Roll Values (MARVs) along with specified testing methods for
  - Physical properties
    - Mass per unit area
    - Thickness
    - Tensile strength
    - UV Resistance
  - Other physical properties (for non-woven below Erosion Mat (if specified))
    - Grab tensile strength
    - Grab elongation
    - Puncture strength
    - Trapezoidal tear
    - UV Resistance

### Inspection and Maintenance

- Areas covered with blankets should be inspected/remediated regularly or in accordance with the PESC and TESC Plans, especially after periods of severe rainfall or storm events, to check for blanket separation or breakage
- Any damaged or poorly performing areas should be repaired/remediated immediately. Regrading of the slope by hand methods may be required in the event of rill or gully erosion.
- Inspection and maintenance should continue until dense vegetation is established
- Areas with low vegetation density should be reseeded
- After approximately one year, a top dressing of fertilizer may be applied to improve vegetation cover and assist degradation of temporary blankets

### Similar Measures

- Mulching (for slopes only)
- Riprap (primarily in channels)
- Gabion mattresses (primarily in channels)

## Rolled Erosion Control Products (RECP)

- a) Channel Installation
- b) Slope Installation
- c) Straw Rolls

## Erosion Control

B.M.P. #13

### Design Considerations

- Assess hydraulic flow conditions and tractive stress on channel
- Assess local soil, weather and growth conditions (favourable/non-favourable) for revegetation (within 3 to 12 months) to allow a determination on use or non-use of RECP as a protective measure. If the revegetation conditions are assessed favourable, the use of RECP can be considered
- Assess suitability of a RECP product using tractive resistance data tested for (i) bare soil, and (ii) vegetated (a specified duration of growth period) condition
- It is noted that tractive resistance data are adopted as selection criteria of RECP and permissible velocity data can be provided for reference.

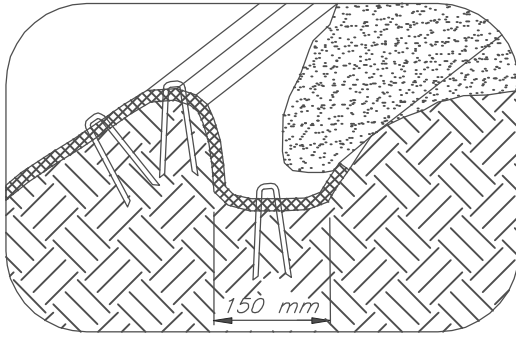

LONGITUDINAL ANCHOR TRENCH

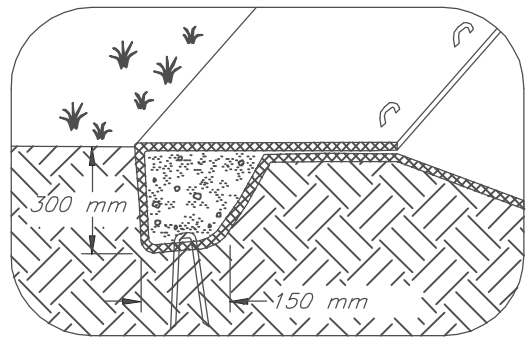

TERMINAL SLOPE AND CHANNEL ANCHOR TRENCH

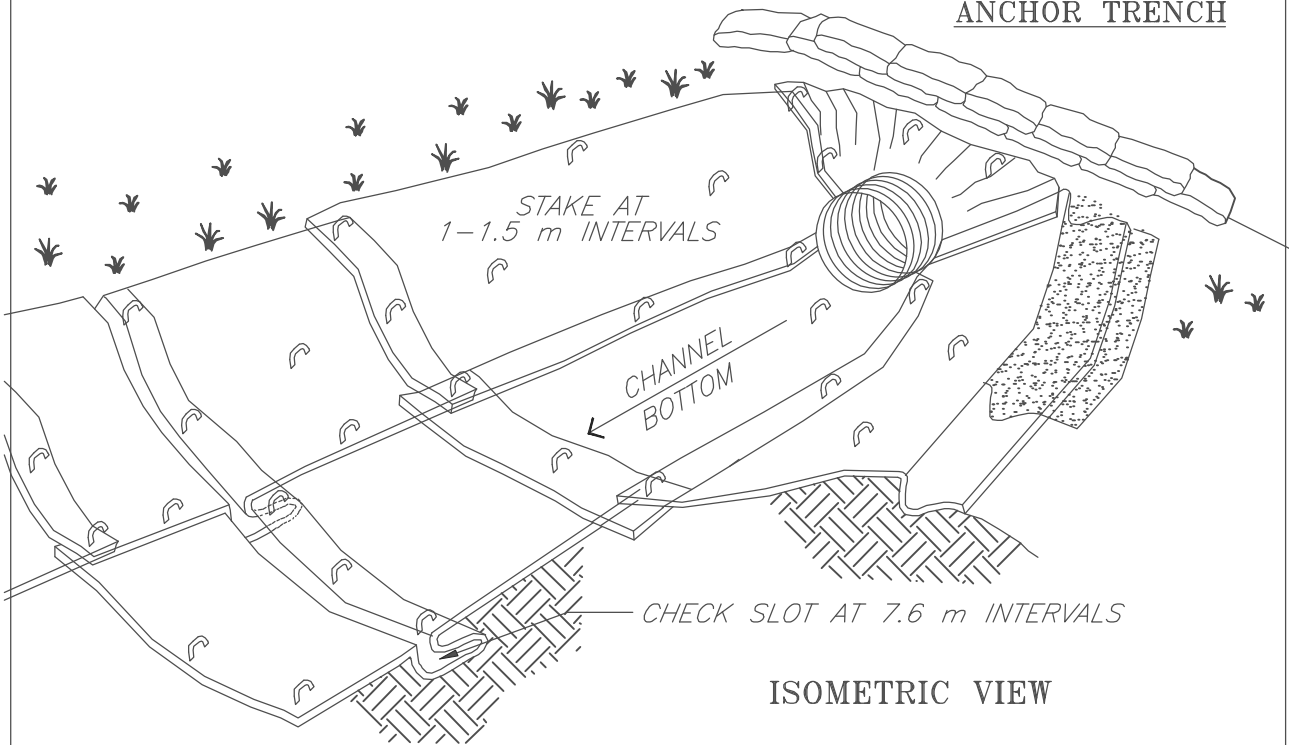

ISOMETRIC VIEW

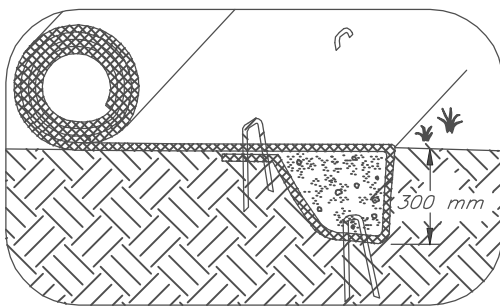

INITIAL CHANNEL ANCHOR TRENCH

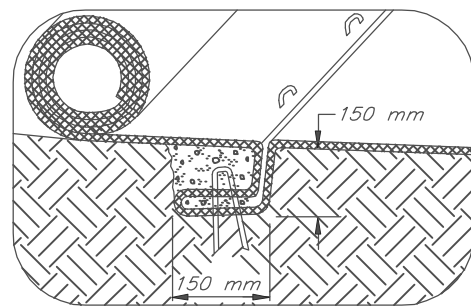

INTERMITTENT CHECK SLOT

**NOTES:**

1. CHECK SLOTS TO BE CONSTRUCTED PER MANUFACTURERS SPECIFICATIONS.
2. STAKING OR STAPLING LAYOUT PER MANUFACTURERS SPECIFICATIONS.
3. THIS FIGURE IS PROVIDED FOR GUIDANCE ONLY AND DOES NOT CONSTITUTE A DESIGN. A SITE SPECIFIC DESIGN IS REQUIRED FROM DESIGNER/ENGINEER.

**ROLLED EROSION CONTROL PRODUCTS (RECP)  
CHANNEL INSTALLATION**

From: Salix-Applied Earthcare - EROSION DRAW 3.0  
1994 JOHN McCULLAH FILE: BLNKTCHA



MATS/BLANKETS SHOULD BE INSTALLED VERTICALLY DOWNSLOPE.

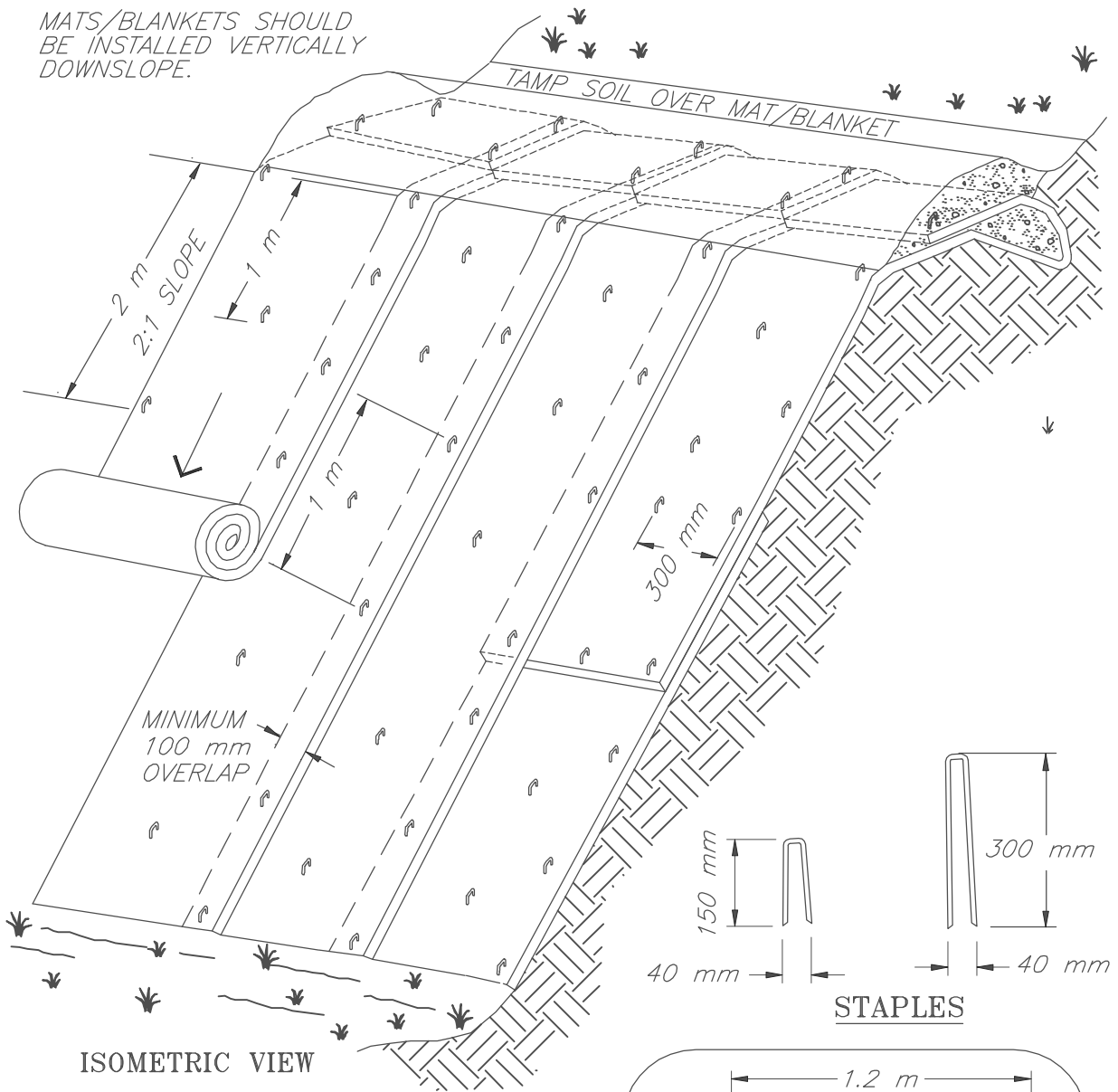

**TYPICAL SLOPE  
SOIL STABILIZATION**

**NOTES:**

1. SLOPE SURFACE SHALL BE FREE OF ROCKS, CLODS, STICKS AND GRASS. MATS/BLANKETS SHALL HAVE GOOD SOIL CONTACT.
2. APPLY PERMANENT SEEDING BEFORE PLACING BLANKETS.
3. LAY BLANKETS LOOSELY AND STAKE OR STAPLE TO MAINTAIN DIRECT CONTACT WITH THE SOIL. DO NOT STRETCH.
4. CHECK SLOTS, STAKING, STAPLING AND OTHER CONSTRUCTION DETAILS PER MANUFACTURERS SPECIFICATIONS.
5. THIS FIGURE IS PROVIDED FOR GUIDANCE ONLY AND DOES NOT CONSTITUTE A DESIGN. A SITE SPECIFIC DESIGN IS REQUIRED FROM DESIGNER/ENGINEER.

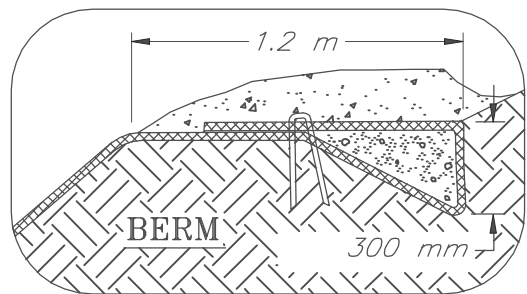

NOT TO SCALE

**ROLLED EROSION CONTROL  
PRODUCTS (RECP)  
SLOPE INSTALLATION**

From: Salix-Applied Earthcare - EROSION DRAW 3.0  
1994 JOHN McCULLAH FILE: BLNKTSLP



## Riprap Armouring

- a) Slope Protection
- b) Channel Protection

## Erosion Control

B.M.P. #14  
(a & b)

### Description and Purpose

- Large, loosely placed cobbles or boulders placed along channel banks or slopes to protect underlying soil from erosion due to flowing water
- Can protect slopes and channel banks against erosion

### Applications

- Permanent measure
- May be used on channel banks and slopes with flow velocities ranging from 2 m/s to 5 m/s (dependent on rock size and thickness); appropriate for slopes that do not exceed 2H:1V
- Riprap only needs to be placed at lower portion of channel section to the anticipated flow height (mean annual peak flow) plus freeboard
  - Other form of soft armouring (RECP blankets, seeding) can be used to promote vegetation to protect soil at upper portion of channel slopes, above riprap
- Must be used in conjunction with a non-woven geotextile underlay acting as a filtration separator with basal soil
- For fluctuating high flow channel, the riprap should be underlain by a layer of granular filter material for cyclic drawdown long-term performance with/without an extra layer of non-woven geotextile as underlay

### Advantages

- Easy to install and easy to repair
- Very durable, long lasting, and virtually maintenance free
- Flexible

### Limitations

- Expensive form of channel lining and stabilization
- Requires heavy equipment and transport of rock to site
- May not be feasible in areas where suitable rock is not available
- Riprap may have to be placed by hand
- Normally 2 to 3 times riprap thickness is required in comparison with gabion mattress thickness for equivalent protection performance under identical hydraulic conditions

## Riprap Armouring

- a) Slope Protection
- b) Channel Protection

## Erosion Control

**B.M.P. #14  
(a & b)**

- Use of gabion is preferred at flow greater than 3 m/s due to larger nominal size of riprap and thickness required for erosion protection during flow velocities of this magnitude
- Can be classified as uniform or graded. Uniform riprap would contain stones which would contain a mixture of stones ranging from small to large. Graded riprap forms a flexible self healing cover

### Construction

- Grade the slope or channel to final design grade
- Place filter (underlay) layer on prepared slope
  - Filter layer can consist of non-woven geotextile underlay and/or well graded granular material dependent on hydraulic conditions
- Place riprap layer
- Riprap should consist of a graded mixture of sound, durable stone with at least 50% of the riprap material being larger than 200 mm in diameter
- Riprap should be sized according to the following gradation and mass:

		Riprap Class			
		1M	1	2	3
<b>Nominal Mass</b>	<b>kg</b>	<b>7</b>	<b>40</b>	<b>200</b>	<b>700</b>
<b>Nominal Diameter</b>	<b>mm</b>	<b>175</b>	<b>300</b>	<b>500</b>	<b>800</b>
None heavier than:	kg or mm	40 300	130 450	700 800	1800 1100
No less than 20% or more than 50% heavier than:	kg or mm	10 200	70 350	300 600	1100 900
No less than 50% or more than 80% heavier than:	kg or mm	7 175	40 300	200 500	700 800
100% heavier than:	kg or mm	3 125	10 200	40 300	200 500

Percentage quoted are by mass.

Sizes quoted are equivalent spherical diameters, and are for guidance only.

Source: AT Bridge Spec. 2010

<b>Riprap Armouring</b> a) Slope Protection b) Channel Protection <b>Erosion Control</b>	<b>B.M.P. #14</b> <b>(a &amp; b)</b>
---	---

- Non-woven geotextile fabric underlay below riprap should meet the following specifications and physical properties:

**Non-Woven Geotextile Filter Fabric  
Specifications and Physical Properties**

	<b>Class 1M, 1 and 2</b>	<b>Class 3</b>
Grab Strength	650 N	875 N
Elongation (Failure)	50%	50%
Puncture Strength	275 N	550 N
Burst Strength	2.1 MPa	2.7 MPa
Trapezoidal Tear	250 N	350 N
Minimum Fabric Overlap to be 300 mm		

Source: AT Bridge Spec. 2010

### **Construction Considerations**

- Riprap should be placed in a uniform thickness across the channel so as not to constrict channel width
- Blasted rock is preferred (if available)
- Riprap layer should be 1.5 to 2 times the thickness of the largest rocks used, 1.5 to 3 times the thickness of the  $D_{50}$  material, and not less than 300 mm in thickness

### **Inspection and Maintenance**

- Inspection frequency should be in accordance with the PESC and TESC Plans
- Periodic inspections to check for erosion of protected material or movement of riprap

### **Similar Measures**

- Rolled erosion control products (RECP) well vegetated; not for use at severe flow and high velocity areas
- Gabion mattresses

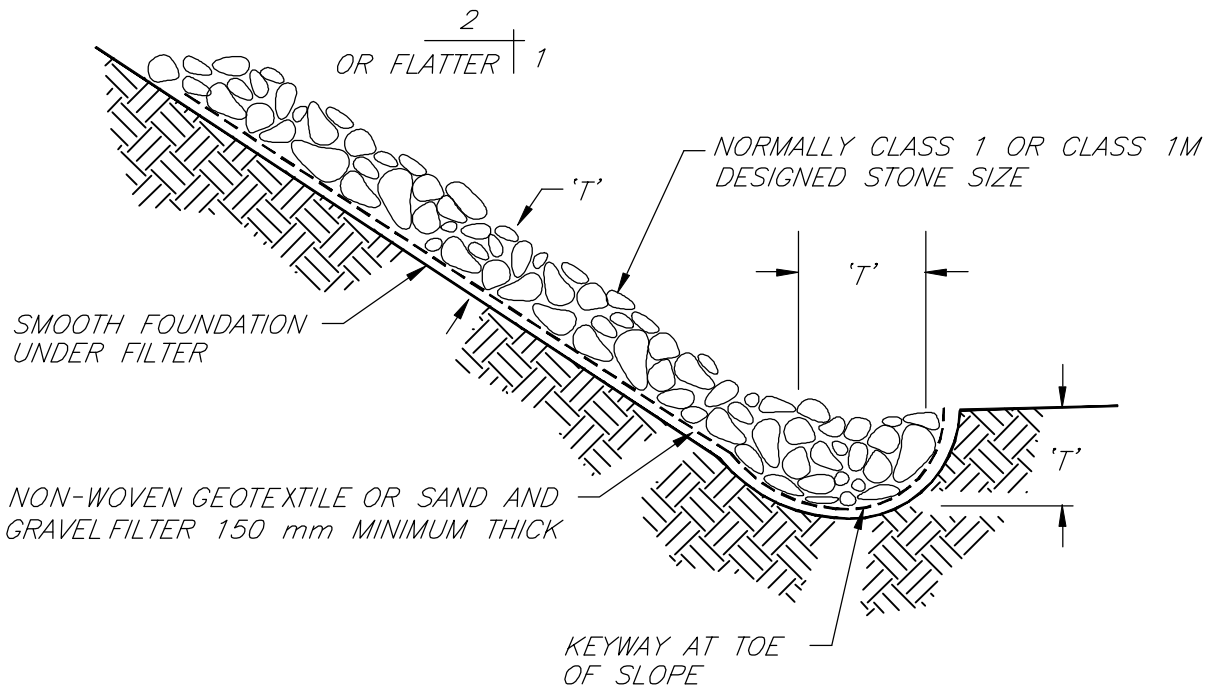

## TYPICAL SECTION

### NOTE:

1. 'T' = THICKNESS: THICKNESS SHALL BE DETERMINED BY THE ENGINEER.  
MINIMUM THICKNESS = 300 mm. (i.e.  $1.5 \times D_{50}$ ) FOR  $D_{50} = 200$  mm.
2. THIS FIGURE IS PROVIDED FOR GUIDANCE ONLY AND DOES NOT CONSTITUTE A DESIGN. A SITE SPECIFIC DESIGN IS REQUIRED FROM DESIGNER/ENGINEER.

**RIPRAP  
ARMOURING  
FOR SLOPE**

DESIGN HEIGHT (H), WIDTH AND STONE SIZE SHALL  
BE DETERMINED BY THE ENGINEER

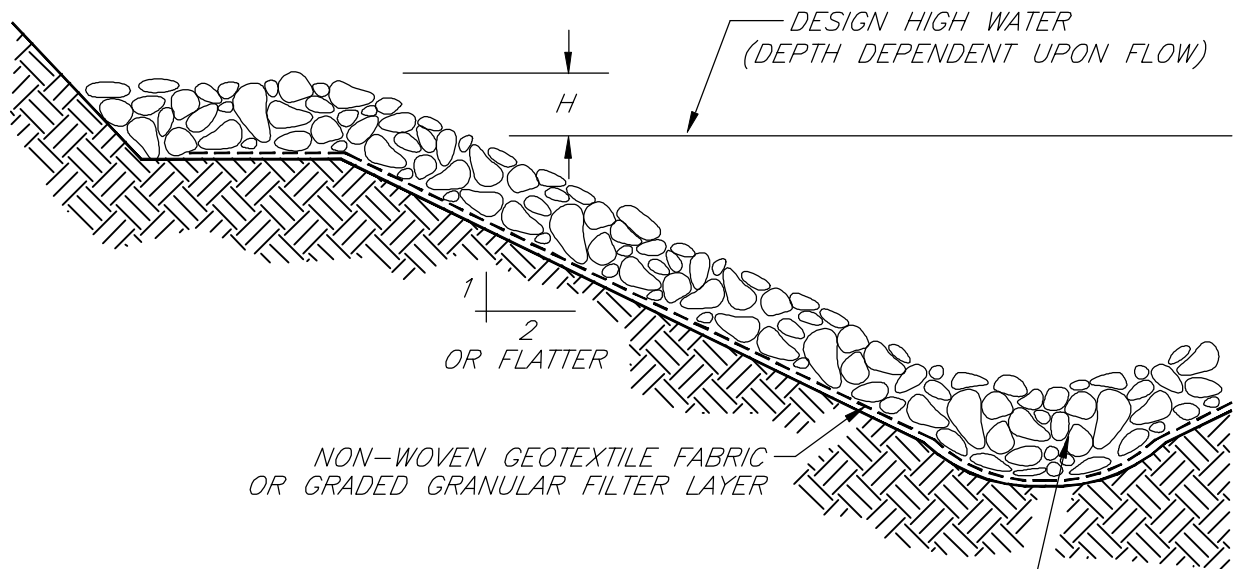

MINIMUM 300 mm THICK LAYER OF 50 mm MINIMUM  
DIAMETER DRAIN ROCK.  $D_{50} = 200$  mm. LARGER STONE SHALL  
BE USED DEPENDENT UPON GRADIENT, SOIL TYPE, AND DESIGN FLOW.

## TYPICAL SECTION

### NOTES:

1. RIPRAP GRADATION AND THICKNESS SHALL BE DETERMINED BY THE ENGINEER IN ACCORDANCE WITH HYDRAULIC CONDITIONS.
2. THIS FIGURE IS PROVIDED FOR GUIDANCE ONLY AND DOES NOT CONSTITUTE A DESIGN. A SITE SPECIFIC DESIGN IS REQUIRED FROM DESIGNER/ENGINEER.

**RIPRAP  
ARMOURING  
FOR CHANNEL**

## Energy Dissipators

- a) for Culvert Outlet
- b) for Trough at Bridge Headslope

B.M.P. #17

## Sediment Control

### Description

- a) Hard armour (riprap, gravel, concrete) placed at pipe outlets, in channels, and at downstream side of check structures to reduce velocity and dissipate energy of concentrated flows (BMP 17a)
- b) Standard Drain Trough Terminal Protection Structure generally used at bridge headslope (BMP 17b)
  - Minimizes scour at flow impact location with dissipated flow energy

### Applications

- Permanent measure
- May be used at outlets of pipes, drains, culverts, conduits, or channels with substantial flows
- May be used at slope drain outlets located at the bottom of mild to steep slopes
- May be used where lined channels discharge into unlined channels
- May be used as splash pad on downstream side of gabions, check structures, berms, barriers, and silt fences to prevent erosion caused by overtopping of structure

### Advantages

- Reduces flow energy in a relatively small area

### Limitations

- Small rocks or stones can be dislodged during high flows
- Grouted riprap may breakup due to hydrostatic pressure, frost heave, or settlement
- May be expensive if construction materials (riprap, gravel, or concrete) is not readily available
- May be labour intensive to place and construct
- Extreme flow velocities may require paved outlet structures, stilling basins, plunge pools, drop structures, baffles, or concrete splash pads which will require special design by qualified personnel. Energy dissipators constructed of riprap may not be adequate for extreme flow velocities

## Energy Dissipators

- a) for Culvert Outlet
- b) for Trough at Bridge Headslope

B.M.P. #17

## Sediment Control

### Construction

- Grade the area to final design grades and elevations
- Sub-excavate energy dissipator location to thickness of energy dissipator
- Place filtration bedding material on base of excavation
  - Bedding can be comprised of well graded sand and gravel or non-woven geotextile
  - Acts as separating filter between fine grained subgrade and riprap size energy dissipator material
- Place energy dissipator material (riprap, gravel, concrete) over filtration bedding material
  - Top of energy dissipator should be flush with surrounding grade

### Construction Considerations

- Length of energy dissipator ( $L_a$ ) at outlets shall be of sufficient length to dissipate energy
  - $L_a = 4.5 \times D$  (where D is the diameter of the pipe or channel at the outlet)
  - Energy dissipator should extend upstream of the outlet approximately a minimum distance of  $0.5 \times D$
- Width of energy dissipator ( $W_a$ ) at outlets shall be of sufficient width to dissipate energy
  - $W_a = 4 \times D$
- Thickness of energy dissipator ( $d_a$ ) at outlets shall be of sufficient thickness to dissipate energy
  - $d_a = 1.5 \times$  maximum rock diameter (with a minimum thickness of 0.30 m)
- Energy dissipator (splash pad, apron) shall be set at zero grade and aligned straight, with the direction of flow at the outlet
- Bedding (filtration) layer can comprise either non-woven geotextile or a minimum of 0.15 m well graded sand and gravel layer
- Energy dissipator should be constructed of well-graded riprap
  - Minimum  $D_{50} = 150$  mm. Preferable  $D_{50} = 300$  mm
  - Minimum thickness = a)  $1.5 \times D_{50}$  or b) 0.30 m to 0.45 m thickness (a or b whichever is greater)

<b>Energy Dissipators</b> a) for Culvert Outlet b) for Trough at Bridge Headslope <b>Sediment Control</b>	<b>B.M.P. #17</b>
--	-------------------



- Energy dissipator shall be designed to accommodate a 10-year peak runoff or the design discharge of the upstream channel, pipe, drain, or culvert, whichever is greater
- The energy dissipator shall be constructed flush with the surrounding grade and shall be directly in line with direction of outlet flow

**Inspection and Maintenance**

- Inspection frequency should be in accordance with the PESC and TESC Plans
- Any damage should be repaired immediately

**Similar Measures**

- Gabion mattresses

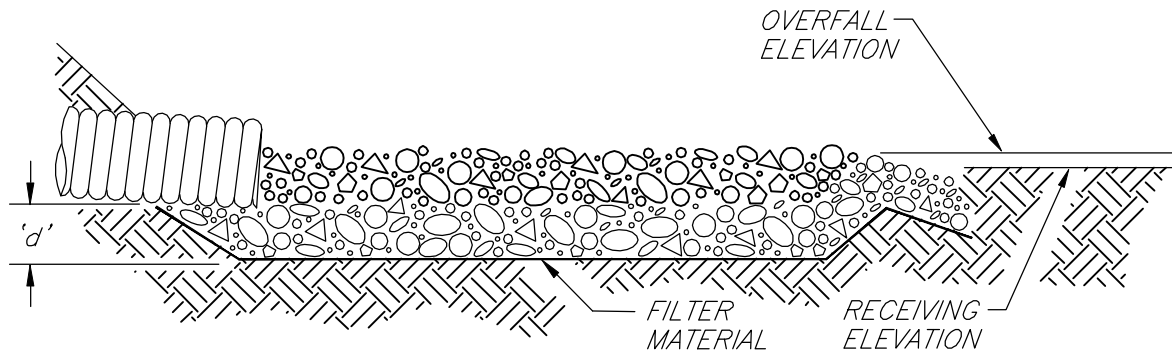

B) MINIMUM THICKNESS = 300 mm. (i.e.  $1.5 \times D_{50}$ ) FOR  $D_{50} = 200$  mm.

### SECTION

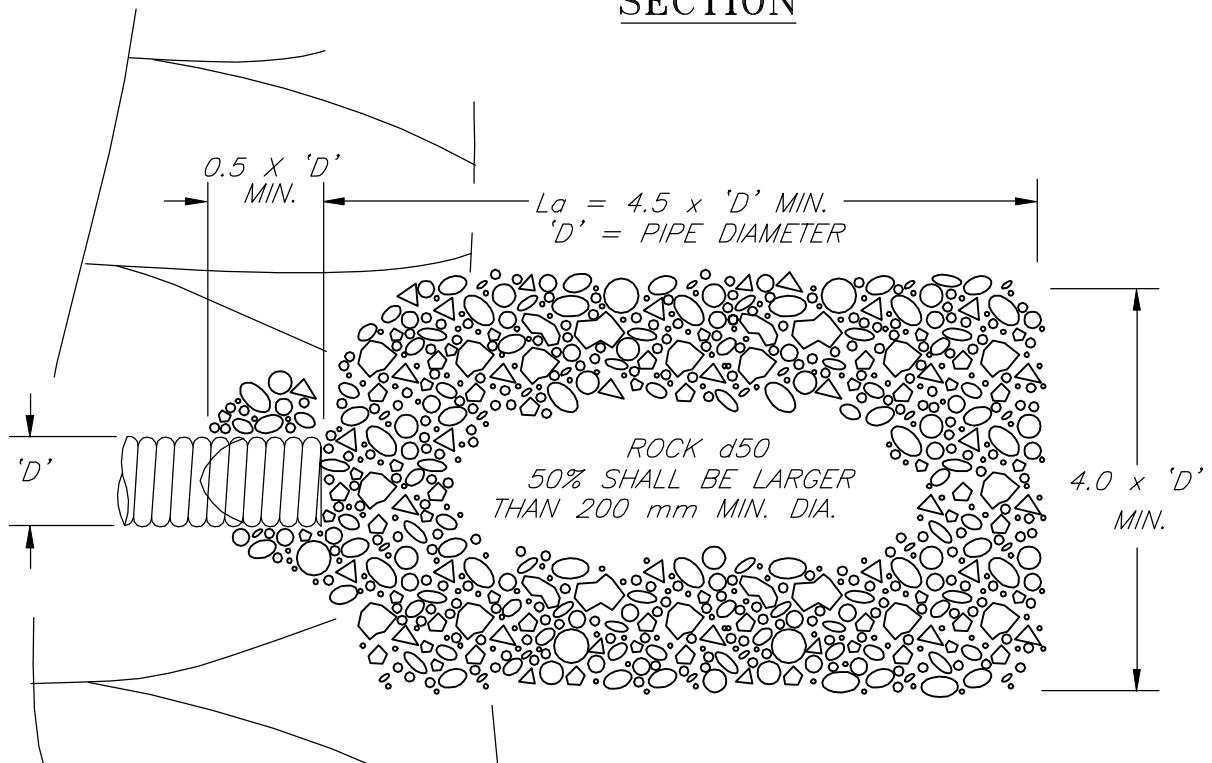

### PLAN

**NOTES:**

1. 'La' = LENGTH OF APRON. DISTANCE 'La' SHALL BE OF SUFFICIENT LENGTH TO DISSIPATE ENERGY.
2. APRON SHALL BE SET AT A ZERO GRADE AND ALIGNED STRAIGHT.
3. FILTER MATERIAL SHALL BE FILTER FABRIC OR 150 mm THICK MINIMUM GRADED GRAVEL LAYER.
4. FOR PIPE DIAMETER > 600 mm, DESIGN BY ENGINEER IS REQUIRED.
5. THIS FIGURE IS PROVIDED FOR GUIDANCE ONLY AND DOES NOT CONSTITUTE A DESIGN. A SITE SPECIFIC DESIGN IS REQUIRED FROM DESIGNER/ENGINEER.

## ENERGY DISSIPATOR FOR CULVERT OUTLET

From: Salix—Applied Earthcare – EROSION DRAW 3.0  
1994 JOHN McCULLAH



FILE: ENRGYDIS

## Sediment Traps and Basins

- a) Riser Outlet Option
- b) Permeable Rock Berm Outlet Option

B.M.P. #18

## Sediment Control

### Description and Purpose

- Low height dam enclosure for impoundment of sediment laden storm water, sedimentation of silt size particles and release of treated storm water
- Used to trap sediment laden run off and promote settlement of sediment prior releasing to enter downstream or watercourses
- Constructed by excavating a pond or building embankments above the original ground surface
- Sediment traps and basins can be divided on size of pond impoundment enclosure
  - Basin (Type I) for pond area  $\geq 500 \text{ m}^2$
  - Trap (Type II) for pond area  $\leq 500 \text{ m}^2$

### Applications

- Permanent measure
- Used at terminal or selective intermediate points of concentrated runoff for impoundment of runoff and sedimentation of silt prior to release of treated runoff downstream
- Used as sedimentation control measure at perimeter of construction sites where sediment laden run off may enter watercourses, storm drains, or other sensitive areas
- Used where there is a need to impound a significant amount of sediment from significant areas of land disturbance
- Sediment basins (Type I) used for disturbed drainage areas greater than 2.0 ha
- Sediment traps (Type II) used for disturbed drainage areas of 2.0 ha, or less
- Where practical, contributing drainage areas should be subdivided into smaller areas and multiple sedimentation impoundment installed

### Advantages

- High capacity of runoff impoundment and more efficient means of sedimentation necessary along perimeters of construction sites with high risk sensitive environmental areas and watercourses
- Sediment can be cleaned out easily
- Robust
- Can be deactivated easily by breaching the enclosure dyke

## Sediment Traps and Basins

- a) Riser Outlet Option
- b) Permeable Rock Berm Outlet Option

B.M.P. #18

## Sediment Control

### Limitations

- Sediment traps and basins do not remove 100% of the sediment; net efficiency for sedimentation of silt may be around 50% dependent on design
- Anticipated service life of 3 years or longer due to possible clogging of outlets in the long-term
- Sedimentation traps and basins with a riser outlet should have an auxiliary spillway with adequate erosion protection to permit overflow in the event that the riser pipe outlet clogs during a storm event
- For drainage areas greater than 40 ha, multiple basins may be required
- Efficiency on sedimentation is very dependent on surface area; sediment basins require large surface areas to permit settling of sediment
- Fences and signage may be required to reduce danger to the public
- May provide breeding habitat for mosquitoes and other pests
- Sediment traps only remove medium and large diameter silt particles and upstream erosion or sediment control measure is required to reduce the amount of sediment laden to the runoff at downstream sensitive areas
- Periodic removal of sediment build up is required

### Construction

- The consequences of failure for any water retaining structure will determine the level of effort in the design and construction phases. The construction guidelines presented herein are minimum requirements. A geotechnical engineer should design water retaining structures if the consequences of failure warrant.
- All footprint area for embankment dyke should be stripped of vegetation, topsoil, and roots to expose mineral subgrade soils
- Embankment fill material should be clean mineral soil with sufficient moisture to allow proper compaction
  - Fill should be placed in lifts not exceeding 150 mm in compacted thickness and should be compacted to a minimum of 95% Standard Proctor maximum dry density (SPD)
- The main outlet structure should be installed at farthest possible point from inlet
  - Outlet should be placed on firm, smooth ground and should be backfilled to 95% SPD
  - Proper inlet and outlet protection should be installed to protect from scour

## Sediment Traps and Basins

- a) Riser Outlet Option
- b) Permeable Rock Berm Outlet Option

B.M.P. #18

## Sediment Control

- Outlet pipe should consist of corrugated steel pipe to protect (against pinching and blockage)
- The embankment should be topsoiled, seeded or protected with gravel or riprap immediately after construction
- Construct an emergency spillway to accommodate flows not carried by the principle outlet
  - Emergency spillway should consist of an open channel (earth or vegetated) over native undisturbed soil (not fill)
  - If spillway is elevated, it should be constructed of riprap
  - Spillway crest should be depressed at least 0.15 m below embankment

### Construction Considerations

- Preferable to strip to mineral soil only along the footprint area required for dyke construction; can leave pond floor centre area cleared but unstripped
- Can be constructed by excavating, constructing embankments, or a combination of the two methods
- Baffles should be provided to prevent short-circuiting of flow from inlet to outlet
- Construct sediment ponds and basins at site perimeter and environmentally sensitive areas prior to wet season and construction activities
- Sediment pond/basin bottom should be flat or gently sloping towards outlet
- Dyke slopes should not be steeper than 2H:1V and should be compacted
- Basins should be located where:
  - Low embankment can be constructed across a swale or low natural terrain
  - It is accessible for maintenance work, including sediment removal

### Inspection and Maintenance

- Regular inspection is required to identify seepage, structural soundness, outlet damage or obstruction and amount of sediment accumulation
- Inspection frequency should be in accordance with the PESC and TESC Plans
- Sediment should be removed upon reaching 1/2 height of the containment berm or within 0.4 m of crest of embankment
- Sediment traps may be deactivated or removed after vegetation of previously disturbed upstream areas has been established

## Sediment Traps and Basins

- a) Riser Outlet Option
- b) Permeable Rock Berm Outlet Option

B.M.P. #18

## Sediment Control

### Design Considerations

- The design can consist of (a) a riser outlet option or (b) a permeable rock berm outlet option. (The permeable rock berm outlet option is preferable for Alberta highway construction)
- Minimum particle size for riprap rock shall be 200 mm
- If the design of a riser outlet is utilized
  - Main outlet pipe shall be fabricated from corrugated steel pipe conforming to CSA Standard CAN 5-G401-M81 or the latest revision thereof
  - Outlet pipe shall consist of a horizontal pipe welded to a similar vertical riser at a 45E mitre joint
- Close to the base of the riser pipe, a 100 mm diameter hole shall be fabricated and a mesh with 12 mm square openings tack welded over the hole as a screen
  - A similar hole shall be provided along the riser pipe immediately above the elevation of the maximum sediment build-up (usually 0.4 m below crest of embankment)

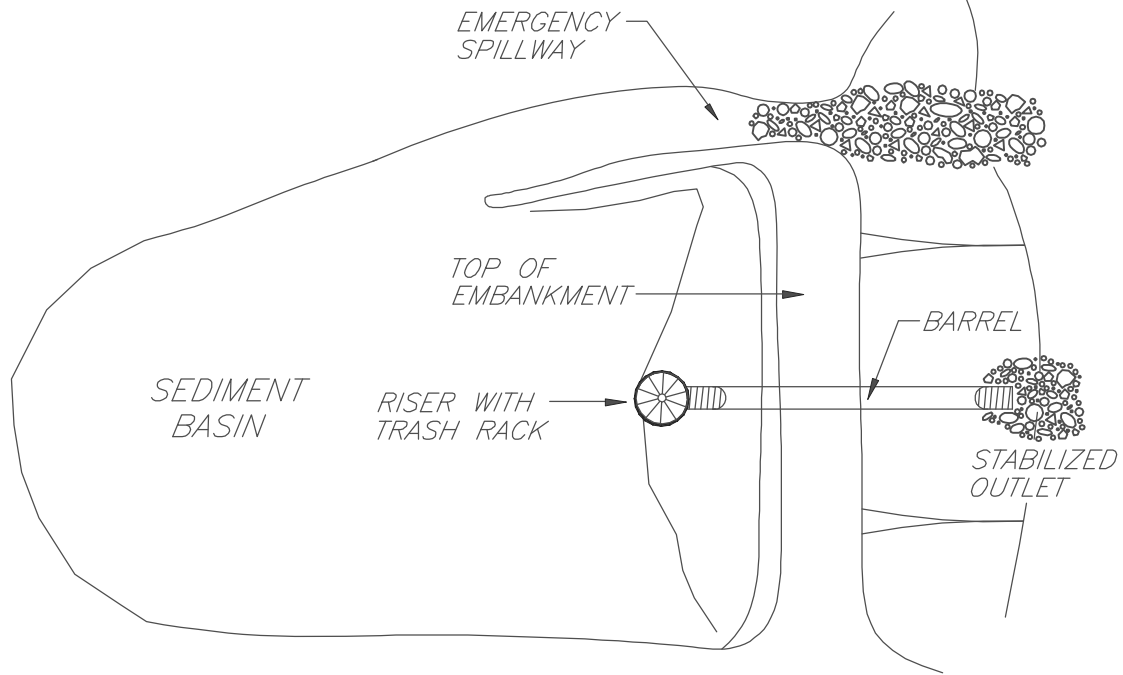

PLAN

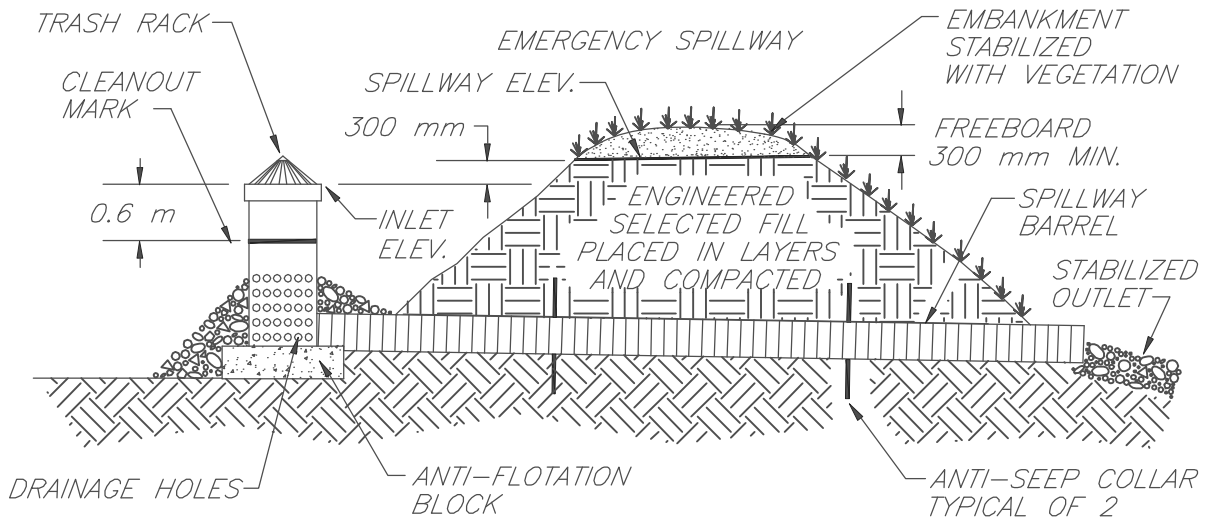

SECTION

NOTES:

1. THE TEMPORARY SEDIMENT BASIN, DESIGNED BY A QUALIFIED PROFESSIONAL, IS REQUIRED FOR DISTURBED AREAS GREATER THAN 2.02 HECTARES (5 ACRES) WITH A DRAINAGE AREA LESS THAN 40.4 HECTARES (100 ACRES).
2. THE SEDIMENT BASIN MAY BE REMOVED WITHIN 3 YEARS.
3. HEIGHT OF ENGINEERED SELECTED FILL EQUAL TO 1 m.
4. FOR CONFIGURATION AND FLOW CHAMBER DESIGN (i.e. LENGTH(L) & WIDTH( $W_e$ ) OF BASIN), REFER TO BMP 18b.
5. THIS FIGURE IS PROVIDED FOR GUIDANCE ONLY AND DOES NOT CONSTITUTE A DESIGN. A SITE SPECIFIC DESIGN IS REQUIRED FROM DESIGNER/ENGINEER.

TYPICAL SEDIMENT  
BASIN  
(RISER OUTLET  
OPTION)

From: Salix-Applied Earthcare - EROSION DRAW 3.0  
1994 JOHN McCULLAH



FILE: SEDBASIN

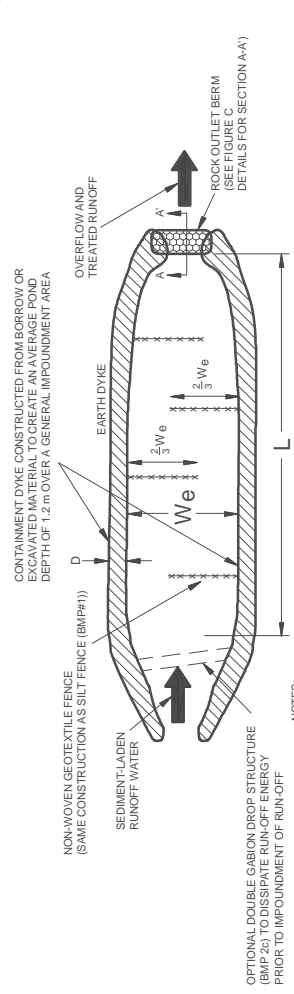

- CONTAINMENT DYKE CONSTRUCTED FROM BORROW OR EXCAVATED MATERIAL TO CREATE AN AVERAGE POND DEPTH OF 1.2 m OVER A GENERAL IMPOUNDMENT AREA
- NON-WOVEN GEOTEXTILE FENCE (SAME CONSTRUCTION AS SILT FENCE (BMP#11))
- SEDIMENT-LADEN RUNOFF WATER
- OPTIONAL DOUBLE GABION DROP STRUCTURE (BMP #2) TO DISSIPATE RUN-OFF ENERGY PRIOR TO IMPOUNDMENT OF RUN-OFF
- OVERFLOW AND TREATED RUNOFF
- ROCK-OUTLET BERM (SEE FIGURE C FOR DETAILS FOR SECTION A-A')
- Notes:
1. CONTRIBUTING RUNOFF AREA SHOULD BE OR SMALLER THAN 2.0 ha.
  2. EFFECTIVENESS APPROPRIATE FOR REMOVING MEDIUM TO COARSE SILT PARTICLES SUSPENDED IN RUNOFF.
  3.  $L/W_e$  RATIO 3:1 CAN BE APPROPRIATE.
  4.  $W_e = 8$  m MINIMUM BOTTOM WIDTH.
  5. NON-WOVEN GEOTEXTILE FABRIC WITH AOS  $\geq 0.15$ mm.

Figure B Type II Containment Structure (Sediment Trap)

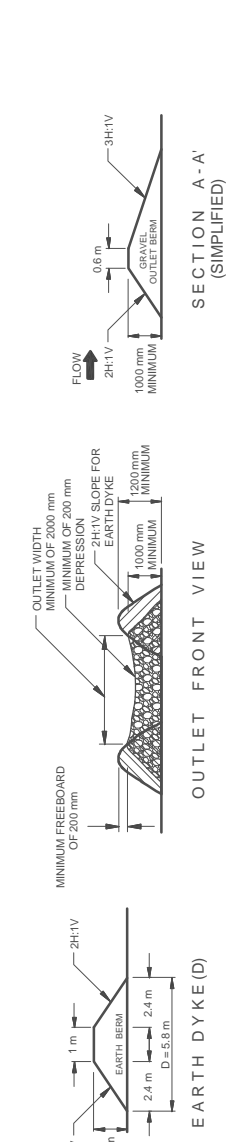
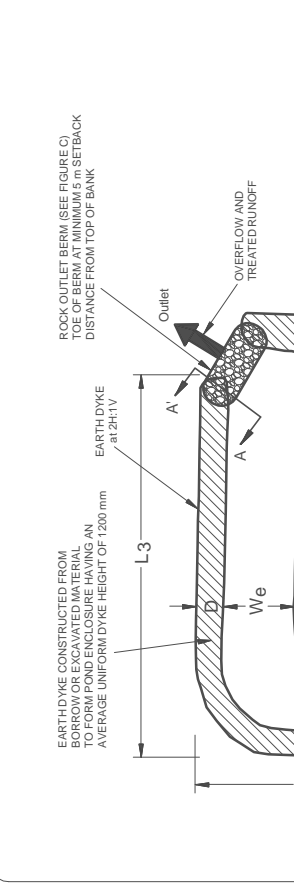

Figure C Section A-A' - Details for Sedimentation Pond (Permeable Structure with Rock Filter Barrier and Perforated Pipe)



- Notes:
1. CONTRIBUTING RUNOFF AREA CAN BE LARGER THAN 2.0 ha BUT LESS THAN 40.0 ha.
  2. EFFECTIVENESS APPROPRIATE FOR REMOVING MEDIUM TO COARSE SILT PARTICLES SUSPENDED IN RUNOFF.
  3. FLOW PATH  $L = L_1 + L_2 + L_3$  FLOW WIDTH  $W_e \geq 6$  m MINIMUM
  4. PROVIDE 1 TO 2 m (1 TO 2% GRADE) ELEVATION DROP BETWEEN INLET AND OUTLET GRADES.
  5. SHAPE OF POND TO CONFORM TO TOPOGRAPHY WITH OUTLET AT MINIMUM 5 m FROM TOP OF BANK.
  6. CONSTRUCTION TO ENSURE SWALES AND BAFFLES ARE TO CHANNEL WATER INTO THE PROPOSED SEDIMENTATION PONDS.

Figure A Type I Sedimentation Pond Containment Structure (Sediment Basin)

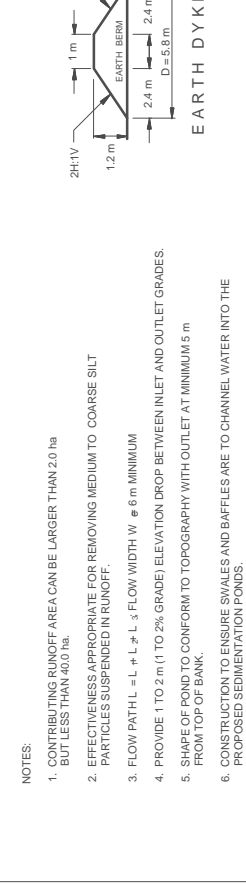

Figure 1 Sedimentation Pond Containment Structure (Sediment Basin)

Notes:

1. DEACTIVATED WITHIN 3 YEARS AFTER SATISFACTORY FULL REVEGETATION OF THE DISTURBED AREA OF POTENTIAL EROSION SOURCES UPSTREAM.
2. THIS FIGURE IS PROVIDED FOR GUIDANCE ONLY AND DOES NOT CONSTITUTE A DESIGN. A SITE SPECIFIC DESIGN IS REQUIRED FROM DESIGNER/ENGINEER.

SOURCE: 1) FIELD (2001) FOR STRUCTURE PLAN  
2) EBA FOR OTHER DESIGN DETAILS

Government of Alberta  
Transportation

B.M.P. #18b  
Typical Section

Seeding	B.M.P. #22
Erosion Control	

### **Description and Purpose**

- The planting or placing seed into soils of cut slope or fill embankment slopes after a layer of organic topsoil is spread over the slope
- Provides erosion protection through development of a shallow root structure from seed germination and plant growth

### **Applications**

- Permanent or temporary measure
- Temporary seeding with rapidly growing plants may be applied to interim stockpile/excavation areas which will be exposed for more than 30 days
- Permanent seeding may be applied to exposed bare soil areas which have been graded to final contours
- Permanent seeding may be applied to landscape corridors, slopes and channels by broadcasting, furrowing or spraying on with mulch tackifier
- Provides habitat for wildlife after vegetation establishment
- Can be enhanced with a protective layer of mulches or rolled erosion control products (RECPs) to improve growth environment

### **Advantages**

- Enhances terrestrial and aquatic habitat with vegetation growth re-establishment
- Aesthetically pleasing with vegetation cover
- Grows stronger with time as root structure develops
- Generates vegetation to enhance infiltration of runoff and transpiration of groundwater
- Seeding with a mixture of grasses and herbaceous legumes in disturbed areas is an inexpensive method of stabilizing the soil, particularly if the area is flat to gently sloping
- Cost of seeding disturbed areas is relatively low and its effectiveness on a long-term basis is relatively high

### **Limitations**

- Grasses may require regular maintenance (mowing) along ditches
- Uncut dry grass may present a fire hazard and site distance obstruction adverse to highway safety

- Seeding of steep slopes may be difficult without using measures such as RECP's or hydroseeding-hydromulching methods
- Seasonal windows on planting (early spring or fall) may not coincide favourably with construction schedule
- Areas that have not been covered with seeded topsoil are susceptible to erosion until vegetation is established if RECPs are not used
- Use of topsoil and mulch can reduce rain drop erosion potential during germination and until vegetation is established
- Additional erosion control measures, such as RECPs, may be required for steep slopes and channels
- Reseeding will be required in areas of limited plant growth
- Time to establish root structure may be unacceptable for some high risk areas; shallow sodding should be considered for these areas

### **Construction**

- The site to be seeded should be prepared prior to seeding
- Surface should be graded to design grades and then topsoiled
- Seedbed should be 75 to 150 mm deep, with the top 75 mm consisting of topsoil free of large clods or stones
- Seed should be applied immediately after seedbed preparation using broadcast seed spreaders, cyclone (broadcast) spreaders, or seed drills to ensure uniformity of application
- Seedbed should be harrowed, raked, or chain-dragged to ensure proper seed-soil contact
- Fertilizer should then be applied after seeding

### **Construction Considerations**

- Seeding rate for all mixes should be 25 kg/ha minimum
- Fall rye may be added to each mix to provide early growth and protection from soil erosion.
- Fall rye seeding rate is 5 kg/ha
- Selection of proper vegetation seed mix depends on soil conditions, climate conditions, topography, land use, and site location

## Seeding

## Erosion Control

B.M.P. #22

- Planting of seeds by hydraulic seeding and mulching techniques should be considered for slopes steeper than 3H:1V where seedbed preparation is difficult, or where application of seed, mulch, and fertilizer in one continuous operation is desirable
- Sod may be installed for faster results, however it is very costly but essential for high risk sensitive areas
- If mulch is placed as a germination medium for seeds, the mulch layer may be further protected with a biodegradable matting to prevent mulch from being washed or blown away

### Inspection and Maintenance

- Inspection frequency should be in accordance with the PESC and TESC Plans
- Freshly seeded areas should be inspected frequently to ensure growth is progressing
- Additional stormwater control measures should be considered for areas damaged by runoff
- Reseedings may be required within 1 to 5 year intervals after initial seeding
- Small bare spots may need to be reseeded several times at subsequent years after initial application
- Larger areas may need to be completely retreated
- Cutting or mowing grasses will encourage the establishment and spread of the grass

### Similar Measures

- Hydraulic seeding and mulching
- Sodding

### Design Considerations

- Seed application rate of 25 kg/ha may be used; if fall rye is to be added, it should have an application rate of 5 kg/ha
- When using a seed drill or Brillion seeder, grasses and legumes shall not be planted deeper than 1 cm
- Bacterial inoculants must be used when seeding with legumes
- A specific inoculant shall be used for the legume being seeded in accordance with the supplier's recommendations

Seeding Erosion Control	B.M.P. #22
----------------------------	------------

- Fertilizer, in lieu of a soil test, shall be as stated in the design, or follow supplier's recommendations
- Fertilizer shall be applied at a rate of 50 to 75 kg of nitrogen/ha, depending upon site conditions
- Fertilizer use shall be carefully controlled as this may increase nutrient loading to receiving streams if runoff is not controlled properly
- Seeding shall occur during periods when germination can be successful and plants have sufficient time to become established before the end of the growing season (approximately May 15 to June 1 and/or August 15 to September 15)
- Seeding should not occur after the 50% frost probability date for the site
- Mulch is required when broadcast seeding or if seeding is carried out after the date specified in which fall seeding should not be carried out
- For specific needs of local growth environment, specific design and advice from local seed supplier or Professional Agrologist may be required

Alberta Transportation has adopted seed mixes (provided below) depending on site location. The various areas of the province used in selecting the seed mix are presented (Alberta Transportation Seed Mixture Zones Map).

Seeding	B.M.P. #22
Erosion Control	

**Alberta Transportation  
Grass Seed Mixtures used on Highway and Bridge Projects**

*This Special Provision (Spc\_G039.wpd (2005)) is to be used in conjunction with AT Standard Specification 2.20 "Seeding" and Design Bulletin No. 25. The Consultant must perform the vegetation assessment and the soil testing for fertilizer (if required) as part of his design work.*

Zone 1 - Peace River District - north and west of High Level:

Seed Mix Zone	Native Seed Mix - Zone 1		% by Dry Weight
	Common Name	Latin Name	
1 Wetland Mixedwood	Slender Wheat Grass	<i>Agropyron trachycaulum</i>	40%
	Fringed Brome <sup>(1)</sup>	<i>Bromus ciliatus</i>	15%
	Tufted Hairgrass	<i>Deschampsia cespitosa</i>	15%
	Northern Wheat Grass	<i>Agropyron dasystachyum</i>	10%
	Rocky Mountain Fescue	<i>Festuca saximontana</i>	10%
	Fowl Bluegrass	<i>Poa palustris</i>	10%

Note <sup>(1)</sup>: Fringed Brome seed shall be coated.

Agronomic Seed Mix - Zone 1		
Common Name	Latin Name	% by Dry Weight
Pubescent Wheat Grass	<i>Agropyron trichophorum</i>	40%
Dahurian Wildrye	<i>Elymus dahuricus</i>	22%
Sheep Fescue	<i>Festuca ovina</i>	30%
Perennial Ryegrass	<i>Lolium perenne</i>	8%

Zone 2 - Athabasca District (south of Athabasca) and Grande Prairie District

Seed Mix Zone	Native Seed Mix - Zone 2		% by Dry Weight
	Common Name	Latin Name	
2 Dry Mixedwood	Slender Wheat Grass	<i>Agropyron trachycaulum</i>	35%
	Fringed Brome <sup>(1)</sup>	<i>Bromus ciliatus</i>	20%
	Tufted Hairgrass	<i>Deschampsia cespitosa</i>	10%
	Northern Wheat Grass	<i>Agropyron dasystachyum</i>	15%
	Rocky Mountain Fescue	<i>Festuca saximontana</i>	10%
	Fowl Bluegrass	<i>Poa palustris</i>	10%

Note <sup>(1)</sup>: Fringed Brome seed shall be coated.

Seeding Erosion Control	B.M.P. #22
----------------------------	------------

Agronomic Seed Mix - Zone 2		
Common Name	Latin Name	% by Dry Weight
Pubescent Wheat Grass	<i>Agropyron trichophorum</i>	40%
Dahurian Wildrye	<i>Elymus dahuricus</i>	22%
Sheep Fescue	<i>Festuca ovina</i>	30%
Perennial Ryegrass	<i>Lolium perenne</i>	8%

Zone 3 - Athabasca District (north of Athabasca) and Hwy. Nos. 88, 750, 986

Seed Mix Zone	Native Seed Mix - Zone 3		% by Dry Weight
	Common Name	Latin Name	
3 Central Mixedwood	Slender Wheat Grass	<i>Agropyron trachycaulum</i>	35%
	Fringed Brome <sup>(1)</sup>	<i>Bromus ciliatus</i>	10%
	Tufted Hairgrass	<i>Deschampsia cespitosa</i>	10%
	Canada Wildrye	<i>Elymus canadensis</i>	10%
	Rocky Mountain Fescue	<i>Festuca saximontana</i>	20%
	Tickle Grass	<i>Agrostis scabra</i>	10%
	Fowl Bluegrass	<i>Poa palustris</i>	5%

Note <sup>(1)</sup>: Fringed Brome seed shall be coated.

Agronomic Seed Mix - Zone 3		
Common Name	Latin Name	% by Dry Weight
Pubescent Wheat Grass	<i>Agropyron trichophorum</i>	40%
Dahurian Wildrye	<i>Elymus dahuricus</i>	22%
Sheep Fescue	<i>Festuca ovina</i>	30%
Perennial Ryegrass	<i>Lolium perenne</i>	8%

<b>Seeding</b>  <b>Erosion Control</b>	<b>B.M.P. #22</b>
--	-------------------

Zone 4 - Lethbridge District (east of Hwy 22), Calgary District (east of Hwy 22), and Hanna District

Seed Mix Zone	Native Seed Mix - Zone 4		% by Dry Weight
	Common Name	Latin Name	
4 Mixedgrass and Dry Mixedgrass	Slender Wheat Grass	<i>Agropyron trachycaulum</i>	30%
	Canada Wildrye	<i>Elymus canadensis</i>	15%
	Mountain Brome	<i>Bromus carinatus</i>	15%
	Northern Wheat Grass	<i>Agropyron dasystachyum</i>	10%
	Western Wheat Grass	<i>Agropyron smithii</i>	5%
	Indian Rice Grass	<i>Orzyopsis hymenoides</i>	5%
	Alkali Grass	<i>Puccinellia distans</i>	10%
	Needle and Thread Grass	<i>Stipa comata</i>	10%

Agronomic Seed Mix - Zone 4		
Common Name	Latin Name	% by Dry Weight
Pubescent Wheat Grass	<i>Agropyron trichophorum</i>	32%
Dahurian Wildrye	<i>Elymus dahuricus</i>	30%
Sheep Fescue	<i>Festuca ovina</i>	30%
Cereal Rye	<i>Secale cereale</i>	8%

Zone 5 - Stony Plain, Vermillion, and Red Deer (east of Hwy 22) Districts:

Seed Mix Zone	Native Seed Mix - Zone 5		% by Dry Weight
	Common Name	Latin Name	
5 Central Parkland	Slender Wheat Grass	<i>Agropyron trachycaulum</i>	25%
	Northern Wheat Grass	<i>Agropyron dasystachyum</i>	10%
	Fringed Brome <sup>(1)</sup>	<i>Bromus ciliatus</i>	15%
	Green Needle Grass	<i>Stipa viridula</i>	15%
	Canada Wildrye	<i>Elymus canadensis</i>	10%
	Indian Rice Grass	<i>Orzyopsis hymenoides</i>	10%
	Nuttall's Alkali Grass	<i>Puccinellia nuttalliana</i>	10%
	Western Wheat Grass	<i>Agropyron smithii</i>	5%

Note <sup>(1)</sup>: Fringed Brome seed shall be coated.

Seeding	B.M.P. #22
Erosion Control	

Agronomic Seed Mix - Zone 5		
Common Name	Latin Name	% by Dry Weight
Pubescent Wheat Grass	Agropyron trichophorum	32%
Dahurian Wildrye	Elymus dahuricus	30%
Sheep Fescue	Festuca ovina	30%
Cereal Rye	Secale cereale	8%

Zone 6 -Lethbridge, Calgary, and Red Deer Districts all located west of Hwy 22):

Seed Mix Zone	Native Seed Mix - Zone 6		% by Dry Weight
	Common Name	Latin Name	
6 Lower Foothills	Slender Wheat Grass	Agropyron trachycaulum	30%
	Smooth Wildrye	Elymus glaucus	20%
	Northern Wheat Grass	Agropyron dasystachyum	10%
	Tickle Grass	Agrostis scabra	10%
	Fringed Brome <sup>(1)</sup>	Bromus ciliatus	10%
	Tufted Hairgrass	Deschampsia cespitosa	10%
	Foothills Rough Fescue	Festuca campestris	10%

Note <sup>(1)</sup>: Fringed Brome seed shall be coated.

Agronomic Seed Mix - Zone 6		
Common Name	Latin Name	% by Dry Weight
Pubescent Wheat Grass	Agropyron trichophorum	40%
Dahurian Wildrye	Elymus dahuricus	22%
Sheep Fescue	Festuca ovina	30%
Perennial Ryegrass	Lolium perenne	8%

Seeding

Erosion Control

B.M.P. #22

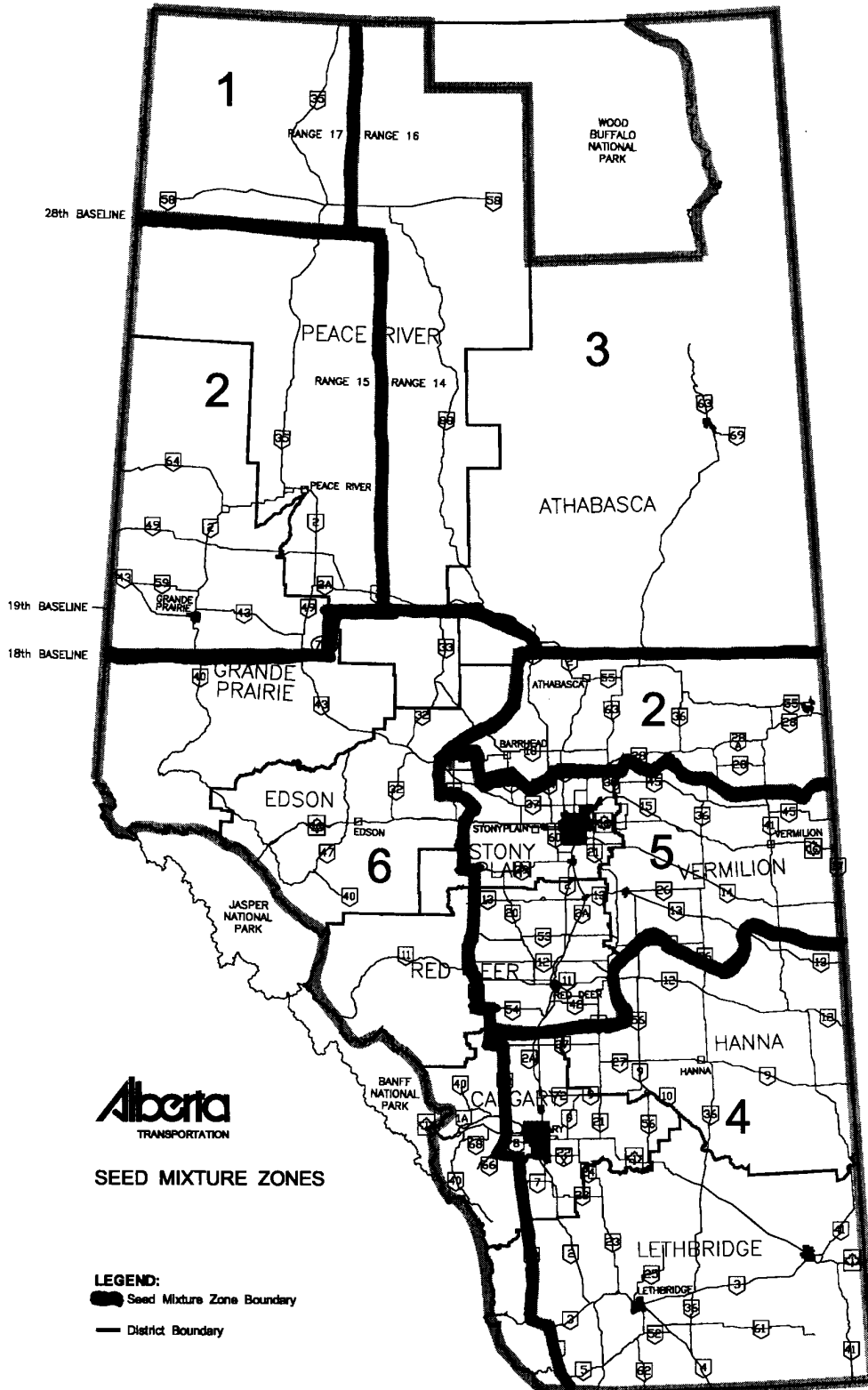

**Description and Purpose**

- Application of organic material or other normally biodegradable substances as a protection layer to the soil surface (i) to minimize raindrop/runoff erosion and conserve a desirable soil moisture property for plant growth, and/or (ii) to promote seed germination and plant growth
- Mulches conserve soil moisture, reduce runoff velocities and surface erosion, control weeds, help establish plant cover, and protect seeds from predators, raindrop impact, and wind/water erosion

**Applications**

- Temporary measure
- Can be used as an organic cover or growth medium for seeds where topsoil is not readily available
- Can be used to provide temporary and permanent erosion control
- May be used with or without seeding in areas that are rough graded or final graded
- May be applied in conjunction with seeding to promote plant growth
- May comprise organic mulches (such as straw, wood fibres, peat moss, wood chips, pine needles, compost) or chemical mulches (such as vinyl compounds, asphalt, rubber, or other substances mixed with water)
- Chemical mulches may be used to bind other mulches in a hydroseeding-hydromulching application

**Advantages**

- Relatively cheap method of promoting plant growth and slope protection

**Limitations**

- Application of mulch may be difficult on steep slopes
- May require spray-on method to apply mulch with tackifier to provide adhesion to steep slopes

**Installation**

- Prepare soil surface by removing large rocks or other deleterious materials
- Apply topsoil and seed, if required, and if topsoil is readily available
- Apply mulch as per supplier's recommendations

- Certain mulches may require additional anchoring to minimize loss of mulch due to wind or water erosion

### **Construction Considerations**

- Install mulches as per manufacturers' or suppliers' recommendations
- Organic Mulches
  - Straw
    - Refers to stalks or stems of small grain (primarily wheat) after drying and threshing
    - Straw should be free of weeds
    - Loose straw is very susceptible to movement by blowing wind and water runoff and should be anchored either with chemical tackifier or some form of netting
    - When properly secured to surface, straw is highly suitable for promoting good grass cover quickly, however, it may be a fire hazard in dry conditions
  - Raw Wood Fibre
    - Mixture of cellulose fibres; a minimum of 4 mm in length extracted from wood
    - Wood fibres usually require a soil binder and should not be used as erosion control during periods of hot dry weather in the summer or for late fall seeding unless it is used in conjunction with another suitable mulch as it is prone to removal by blowing wind or water runoff
    - Wood fibre is primarily used in hydroseeding-hydromulching operations where it is applied as part of a slurry and when used in conjunction with a tackifier; it is well suited for tacking straw mulch on steep slopes
  - Peat Moss
    - Comprises partly decomposed mosses and organic matter under conditions of excessive moisture
    - Usually available in dried and compressed bundles
    - Should be free of coarse material
    - Useful soil conditioner to improve organic content of soil promoting plant growth
    - Highly susceptible to removal by blowing wind and water runoff if dry and spread on top of soil
  - Wood Chips
    - By-products of timber processing comprised of small, thin pieces of wood

- Decompose slowly
- Suitable for placing around individual plants (shrubs and trees) and for areas that will not be closely mowed
- Highly resistant to removal by blowing wind and water runoff
- Bark Chips (Shredded Bark)
  - By-products of timber processing comprised of small, thin pieces of tree bark
  - Suitable for areas that will not be closely mowed
  - Have good moisture retention properties and are resistant to removal by blowing wind and water runoff
- Pine Needles
  - Comprise needles from coniferous trees (pine, spruce)
  - Needles should be air dried and free of coarse material
  - Decompose slowly
  - Suitable for use with plants that require acidic soils
  - Resistant to removal by blowing wind and water runoff
- Compost (Straw Manure)
  - Comprised of organic residues and straw that have undergone biological decomposition until stable
  - Should be well shredded, free from coarse material, and not wet
  - Has good moisture retention properties and is suitable as a soil conditioner promoting plant growth
  - Relatively resistant to removal by blowing wind and water runoff if not dried out completely
- Chemical Mulches
  - Comprised of acrylic co-polymers, vinyl compounds, asphalt, rubber, or other substances mixed with water
  - Usually used in hydroseeding-hydromulching applications
  - Should be applied in accordance with suppliers' recommendations

Mulching Sediment Control and Erosion Control	B.M.P. #23
--	------------

### **Inspection and Maintenance**

- Inspection frequency should be in accordance with the PESC and TESC Plans
- Areas damaged by washout or rilling should be regraded if necessary and recovered with mulch immediately
- Additional stormwater control measures should be considered for areas of severe rilling erosion damaged by runoff
- Small bare spots may need to be reseeded and recovered with mulch

### **Similar Measures**

- Topsoiling
- Hydraulic seeding and mulching (hydroseeding, hydromulching)
- Rolled erosion control products (RECP)

**Description and Purpose**

- The spraying-on of a slurry to a slope or channel surface to provide a layer of seed and growth bedding medium
- The slurry consists of seed, fertilizer, mulch, tackifiers, and water which are mixed together in a tank
- Enables quick re-vegetation of very steep or rocky/gravelly slopes where re-vegetation by any other method would be very difficult or unsafe; frequent re-seeding and special mix design may be required
- When sprayed on the soil, the slurry forms a continuous blanket with seeds and protects the soil from wind and water erosion and raindrop impact by aggregating (or adhering) them in place
- The slurry conserves moisture, reduces soil moisture evaporation, and decreases soil surface crusting due to evaporation or drying of soil

**Applications**

- Temporary measure
- Slurry is held in suspension through consistent agitation and is sprayed onto disturbed areas using high pressure pumps
- Can be used for spray-on seeding covering large areas efficiently after placement of topsoil
- Can be used to provide temporary and permanent erosion control prior to establishment of vegetation
- May be used to provide soil stabilization for seeding disturbed soil areas
- Can also be used with higher efficiency and large area coverage with advantages over conventional methods (broadcast seeders, drill seeders)
- Can be used in areas where little topsoil is available

**Limitations**

- Site must be accessible to hydroseeding equipment
  - Usually mounted on trucks
  - Maximum hose range of approximately 150 m
- May require subsequent spraying to reseed bare spots or areas with low growth

# Hydroseeding

## Sediment Control and Erosion Control

B.M.P. #24a

### Construction

- Prepare soil surface by removing large rocks or other deleterious materials
- Apply topsoil if available
- Spray on hydroseed-hydromulch as per supplier's recommendations

### Construction Considerations

- Seed
  - Seed selection should be made in accordance with Alberta Transportation approved seed mixes
  - Alberta Transportation has adopted seed mixes used on Alberta Highway and Bridge Projects depending on site location (see BMP #22 Seeding)
  - The various areas of the province used in selecting the seed mix are presented in the Seed Mix Zones map (see BMP #22 Seeding)
  - Seed mixes have been developed based on historic performance results throughout Alberta

### Inspection and Maintenance

- Inspection frequency should be in accordance with the PESC and TESC Plans
- Areas damaged by runoff may need to be repaired and/or protected from further erosion
- Small bare spots may need to be reseeded

### Similar Measures

- Seeding
- Mulching
- Rolled erosion control products (RECP)

**Description and Purpose**

- The spraying-on of a slurry to a slope or channel surface to provide a layer of growth bedding medium
- The slurry consists of seed, fertilizer, mulch, tackifiers, and water which are mixed together in a tank
- The slurry conserves moisture, reduces soil moisture evaporation, and decreases soil surface crusting due to evaporation or drying of soil

**Applications**

- Temporary measure
- Can be used in areas where little topsoil is available

**Advantages**

- Relatively cheap and efficient spraying method of promoting plant growth as well as erosion protection
- Allows spray-on re-vegetation of steep slopes where conventional re-vegetation methods are very difficult
- Minimizes effort required to re-vegetate disturbed areas as hydromulching usually only requires one spray-on operation in comparison with planting and farrow method
- Relatively efficient operation with high coverage rates
- Provides dust control and protection from wind erosion

**Limitations**

- Site must be accessible to hydromulching equipment
  - Usually mounted on trucks
  - Maximum hose range of approximately 150 m

#### **Construction**

- Prepare soil surface by removing large rocks or other deleterious materials
- Apply topsoil if available
- Spray on hydromulch as per supplier's recommendations

#### **Construction Considerations**

- Hydraulic Mulches
  - Cellulose
    - Comprised of recycled paper from newspapers, magazines, or other paper sources
    - Rapid method for applying seed, fertilizer, mulch, and water in almost any disturbed areas
    - Usually installed without tackifier in slurry
    - Short fibre lengths and lack of tackifier limits erosion control effectiveness and does little to moderate moisture content and temperature within the soil
    - Residual inks within the recycled paper may leach into soil, potential problem on environmentally sensitive areas
    - Longevity significantly shorter than for wood fibre mulches or bonded fibre matrices (BFM)
    - Cheaper than wood fibre mulches and bonded fibre matrices (BFM)
  - Wood Fibre
    - Comprised of whole wood chips
    - Industry standard, provides quick and uniform method and medium for re-vegetating large areas quickly and economically
    - Longer fibre lengths than for cellulose mulches
    - Longer lasting and has better wet-dry characteristics than cellulose mulches
    - Provides limited erosion control even when sprayed on with tackifiers
    - Provides limited moderation of soil moisture content and temperature when applied at higher rates
    - Cheaper than BFM, however, less effective than BFM
    - More expensive than cellulose mulches, however, more effective than cellulose mulches

#### – Bonded Fibre Matrices (BFM)

- Slurry comprised of either cellulose mulch, wood fibre mulch, or a combination of the two
  - Mulches are bound together using chemical bond, mechanical bond, or a combination of the two
  - All fibres and binding agents are premixed by manufacturer, ensuring uniformity and consistency throughout the application
  - Well suited for sites with existing desirable vegetation and where worker safety and minimal ground disturbance are desired
  - Degree of protection similar to that obtained from rolled erosion control products (RECP)
  - Quicker installation/application than for RECP
  - Chemically bonded BFM may require a ‘set-up’ or curing/drying period
    - Application must be limited to periods where there is no threat of rain during curing period
    - Mechanically bonded BFM have no curing time and are effective immediately after application
  - Application on dry soils is not recommended
  - More expensive than cellulose and wood fibre mulches
  - More effective than cellulose or wood fibre mulches
- Tackifiers
    - May include vinyl compounds, asphalt, rubber, or other substances mixed with water

#### **Inspection and Maintenance**

- Inspection frequency should be in accordance with the PESC and TESC Plans
- Areas damaged by runoff may need to be repaired and/or protected from further erosion.

#### **Similar Measures**

- Seeding
- Mulching
- Rolled erosion control products (RECP)

### **Description and Purpose**

- Consists of installing woody plantings (trees and shrubs) to develop a root matrix within the soil, increasing subsurface soil strength and stabilizing slopes with deeper root systems than grasses
- Reduces erosion potential of slopes and channel banks

### **Applications**

- Temporary or permanent measure
- May be used on slopes stable enough to support vegetation; however, there is a low success rate for steep slopes and channel banks with gradients greater than 1H:1V
- May be used on slopes and channel banks with adequate sunlight, moisture, and wind protection to support vegetation
- May be used as bio-engineering stabilization in cases where there have been historical shallow slope instability, soil movements on eroded slopes and gullies
- May be used along channels to provide higher channel roughness to reduce flow velocity and in sedimentation ponds to provide higher sedimentation duration of runoff impoundment

### **Advantages**

- Promotes development of organic mat
- Dense leaves and large diameter plant stalks increases channel roughness and reduces flow velocities in channel thus decreasing erosion potential
- Traps sediment laden runoff and stabilizes soil
- Aesthetically pleasing once developed
- Grows stronger with time as root structure develops
- Usually has deeper root penetration than grass with greater depth of stabilization
- Manual planting may be attempted on steep slopes that are sensitive to machinery disturbance or represent an area of high erosion potential

### **Limitations**

- Can be labour intensive to install
- Some level of uncertainty as success of plant growth is dependent on various unknown site parameters (i.e., moisture, soil, terrain, weather, seeding conditions, etc.)
- Re-vegetated areas are susceptible to erosion until vegetation develops; and should be used in conjunction with hydroseeding and/or mulching
- Plants may be damaged by wildlife
- Potential for low success rate
- Few precedents as this measure is generally not used on AT construction projects

### **Construction**

- Used on cut or fill slopes or in ditches/channels
- Comprised of willow or poplar stakes inserted into the ground; other indigenous plants may be acceptable
- Individual dormant willow or poplar stakes should be cut to a minimum length of 0.5 m using pruning shears
  - Cuts should be made at a 45° angle a minimum of 0.05 m (5 cm) below a leaf bud
  - All side shutes should be trimmed to within 0.05 m of the main stem
- Install live stakes in a 1 m by 1 m grid
- Make a pilot hole a minimum of 0.3 m in depth to insert live stake into
  - Use iron bar, broom handle or other tool to make pilot hole
- Insert live stake into pilot hole and lightly tamp soil around live stake
- A minimum of two leaf buds should remain above grade

### **Construction Considerations**

- Successful installation requires the use of freshly cut branches or stakes
  - Storage time of cut branches/stakes on-site prior to installation should be kept to as short a time period as possible
- Successful growth dependant on soil moisture and rainfall conditions
- Consultation with agrologist, greenhouse growers, local expertise can be beneficial in selecting and procuring appropriate species for planting

<p>Live Staking</p> <p>Streambank Stabilization Technique</p>	<p>B.M.P. #27a</p>
---	--------------------

### **Inspection and Maintenance**

- Inspection frequency should be in accordance with the PESC and TESC Plans
  - Areas damaged by washout or erosion rilling should be replanted immediately
- Additional stormwater control measures should be considered for severe rilling areas damaged by runoff
- Watering plants is required for first one to two months after planting

### **Similar Measures**

- Seeding
- Mulching
- Hydroseeding
- Hydromulching
- Rolled erosion control products (RECP)
- Brush layering

TYPICAL USE OF WILLOW STAKES TO ANCHOR WILLOW WATTLES, STRAW ROLLS, BIO MATS, OR TURF REINFORCEMENT MATS

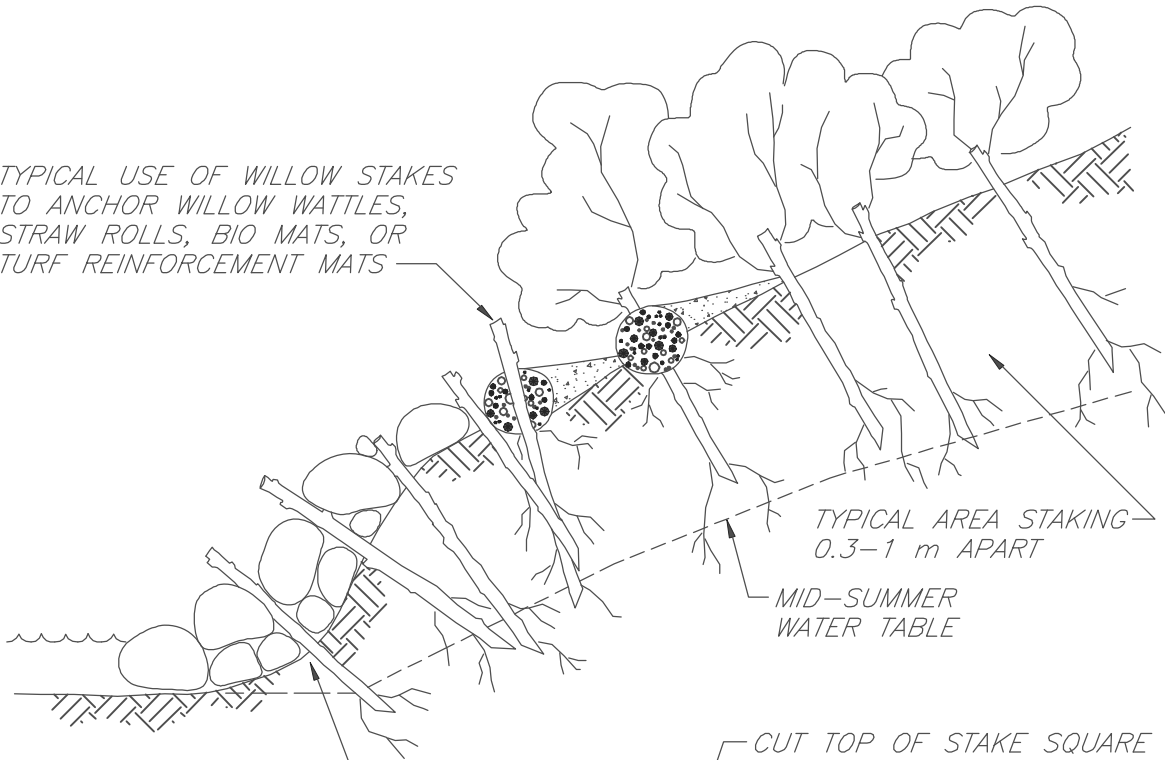

TYPICAL - DRIVE OR PLANT WILLOW STAKES THROUGH OPENINGS IN RIPRAP OR GABIONS

PLANT 80% OF STAKE LENGTH INTO THE GROUND

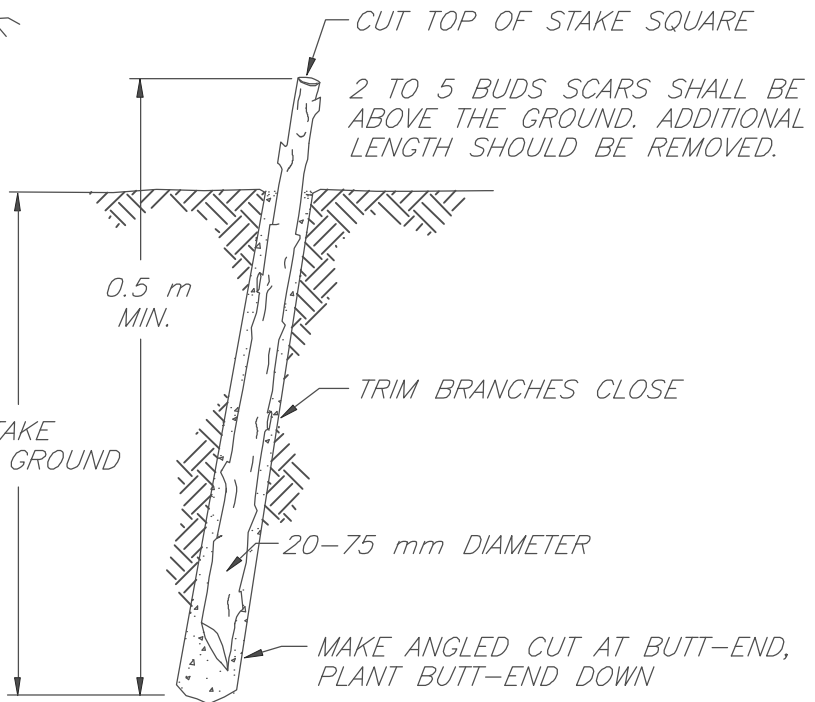

NOTES:

1. HARVEST AND PLANT STAKES DURING THE DORMANT SEASON.
2. USE HEALTHY, STRAIGHT AND LIVE WOOD AT LEAST 1 YEAR OLD.
3. MAKE CLEAN CUTS AND DO NOT DAMAGE STAKES OR SPLIT ENDS DURING INSTALLATION, USE A PILOT BAR IN FIRM SOILS.
4. SOAK CUTTINGS FOR 24 HOURS (MIN.) PRIOR TO INSTALLATION.
5. TAMP THE SOIL AROUND THE STAKE.
6. THIS FIGURE IS PROVIDED FOR GUIDANCE ONLY AND DOES NOT CONSTITUTE A DESIGN. A SITE SPECIFIC DESIGN IS REQUIRED FROM DESIGNER/ENGINEER.

NOT TO SCALE

LIVE STAKING

From: Salix-Applied Earthcare - EROSION DRAW 3.0  
1996 JOHN McCULLAH



FILE: LIVESTK

### **Description and Purpose**

- The extraction of sediment is effected by pumping sediment laden runoff into a bag manufactured with a permeable geotextile. Water will filter through the filter bag with the sediment being retained within the filter bag

### **Applications**

- Temporary measure
- Can be used in high risk areas to supplement performance of containment pond systems
  - An example area would be where containment pond space is limited on construction site and appropriate sized containment pond cannot be constructed adjacent to high risk areas
- Useful for additional extraction of sediment dewatering sumps, sediment ponds, or other retention facilities with accumulations of sediment laden runoff

### **Advantages**

- Filter bag is lightweight and portable
- Simple cleanup and disposal
- Sediment is captured within filter bag for removal from site

### **Limitations**

- May be expensive
  - Extra costs associated with cost of filter bags and costs of pumping out retention facilities
- Power supply for pumps may be required
- Useful for only short periods of time and small volumes of water
- Can only retain particle sizes larger than the Apparent Opening Size (AOS) of the filter fabric bag
- Refer to manufacturers' product performance information
- Generally for available non-woven filtration geotextile, AOS values of 0.15 mm range or lower can be realistically manufactured. Potentially, only particle size larger than the design AOS value can be removed from the bag types. It is important to require manufacturer to provide performance specification and physical properties of the bags. The designer and supplier of the filter bag should choose

<b>Pumped Silt Control Systems (Filter Fabric Bags) Sediment Control and Erosion Control</b>	<b>B.M.P. #31</b>
--	-------------------

the fabric and AOS based on the anticipated gradation of the sediments to ensure the sediments are retained in the bag.

- Few precedents as this measure is generally not used on AT construction projects, however, it can be resorted as emergency measure for highly sensitive sites

### **Implementation**

- Place filter bag on free-draining base (such as gravel pad or straw pile) on a slight slope, with opening to silt bag facing upslope
- Attach hose to opening of filter bag
  - Ensure tight seal to prevent discharge of sediment laden runoff outside of bag
- Attach hose to pump and insert extraction hose into retention facility to be dewatered
- Turn on pump and remove sediment laden water until filter bag is full of sediment
- Disengage pump once filter bag is full, tightly close opening to filter bag to prevent spilling of sediment and remove bag
- Repeat process (using new filter bags) until retention facility is dewatered to acceptable levels

### **Implementation Considerations**

- Full filter bags can be removed from site or buried in designated locations on-site
- Care should be taken to ensure filter bag is not overfilled, which may cause filter bag to tear, spilling sediment
- Care should be taken when transporting full filter bags to ensure filter bag is not torn

### **Inspection and Maintenance**

- Inspect all hoses and connections before and during pumping operations to minimize leaks

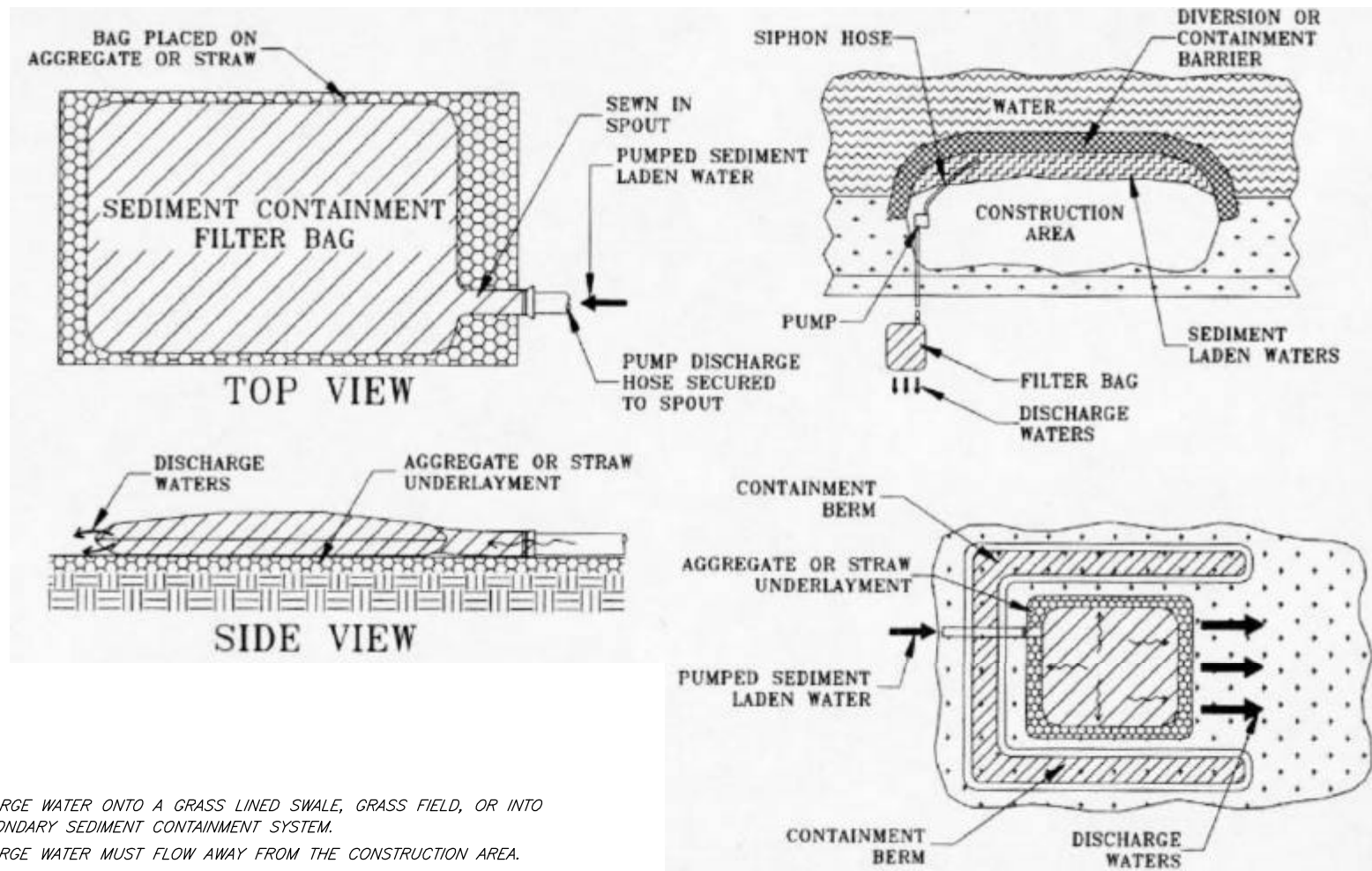

**NOTES:**

1. DISCHARGE WATER ONTO A GRASS LINED SWALE, GRASS FIELD, OR INTO A SECONDARY SEDIMENT CONTAINMENT SYSTEM.
2. DISCHARGE WATER MUST FLOW AWAY FROM THE CONSTRUCTION AREA.
3. SEDIMENT CAPTURED BY THE FILTER BAG MUST BE REMOVED AND STABILIZED.
4. THIS FIGURE IS PROVIDED FOR GUIDANCE ONLY AND DOES NOT CONSTITUTE A DESIGN. A SITE SPECIFIC DESIGN IS REQUIRED FROM DESIGNER/ENGINEER.

SOURCE: FIFIELD 2001

**PUMPED SILT CONTROL SYSTEM**

**Description and Purpose**

- Texturing of slopes, either by roughening the surface, tracking the surface, or installing grooves or benches
  - Texturing reduces the runoff velocity, traps sediment, and increases the infiltration of water into the soil
- a) Surfacing Roughening
  - b) Grooved or Serrated Slope
  - c) Benched Slope

**Applications**

- Temporary measure
- May be used to roughen the exposed soils on the slope surface in the direction of water flow to minimize erosion and to entrap some sediments
- May be used on fresh cut or fill slopes (8 m length or longer; practical travel reach of a dozer) with gradients of generally 3H:1V or steeper (2H:1V as general steepness limit) constructed in cohesive soils
- May be used on slope subgrade that will not be immediately topsoiled, vegetated or otherwise stabilized
- May be applied to topsoiled slope to provide track serration to further reduce erosion potential
- May be used in graded areas with smooth and hard surfaces
- As part of slope design, benching may be used to effect a reduction of erosion hazard where a long slope length needs to be shortened into smaller sectional lengths with mid-benches; normally a 3 m wide bench can be appropriate
  - Benching is usually a permanent slope design feature and should only be designed by a qualified geotechnical engineer
  - Benching of a long slope section to divide into short sections can reduce erosion hazard in the range of 30 to 50% (e.g., sediment yield for 15 m high 3H:1V slope with mid-bench)

### Advantages

- Reduces erosion potential of a slope
- Texturing will create protrusions to increase surface roughness to reduce overland flow velocities and erosion energy
- Texturing will create minor spaces to entrap a portion of the coarse sediment and reduces amount of sediment transported downslope
- Texturing of slopes will benefit development of vegetation
- Texturing of slopes aids in performance of mulches and hydroseeding
- Texturing with track-walking up/downstream may effect a 50% reduction of sediment yield compared with untracked slope

### Limitations

- Surface roughening and tracking may increase grading costs
- Surface roughening and tracking may cause sloughing in certain soil types (i.e., sandy silt) and seepage areas; geotechnical advice is recommended
- Texturing provides limited sediment and erosion control and should be used as a temporary measure prior to topsoiling
  - Should be used in conjunction with other erosion and sediment control measures (i.e., offtake ditches) to limit the sheet flow downslope

### Construction

- Surface Roughening
  - Leave soil in rough grade condition, do not smooth grade soil
  - Large lumps of soil will aid in decreasing runoff velocities, trap sediment, and increase infiltration of water
- Surface Tracking
  - Using tracked construction equipment to move up and down the slope, leaving depressions perpendicular to the slope direction; limit passes to prevent overcompaction of the surface
  - Depressions in the soil will aid in decreasing runoff velocities, trap sediment, and increase infiltration of water
- Grooving
  - Excavating shallow furrows across the width of the slope, perpendicular to the direction of the slope

Slope Texturing (a-c)	B.M.P. #34 (a - c)
Sediment Control	

- If used, contour grooves should be approximately 0.1 to 0.2 m in depth
- Grooves can be made by using equipment or hand
- Benching
  - Construction of narrow, flatter sections of soil on the slope, perpendicular to the direction of the slope
  - Benches should be designed by qualified geotechnical engineer

### Construction Considerations

- During tracking operations, care must be taken to minimize disturbance to the soil where the equipment turns or changes direction
- Minimize the number of tracking passes to 1 or 2 times to avoid overcompaction, which can negatively impact the vegetation growth
- It is practical to track roughen a slope length of greater than 8 m for practical up/down slope operation of a small bulldozer. It is important to minimize the loosening of soil caused by turning movement of the bulldozer at the end of each pass. As the erosion potential is lower for slope of low vertical height (<3 m height and 3H:1V slope), the tracking of low height slope is not required and not practical for bulldozer tracking operation.

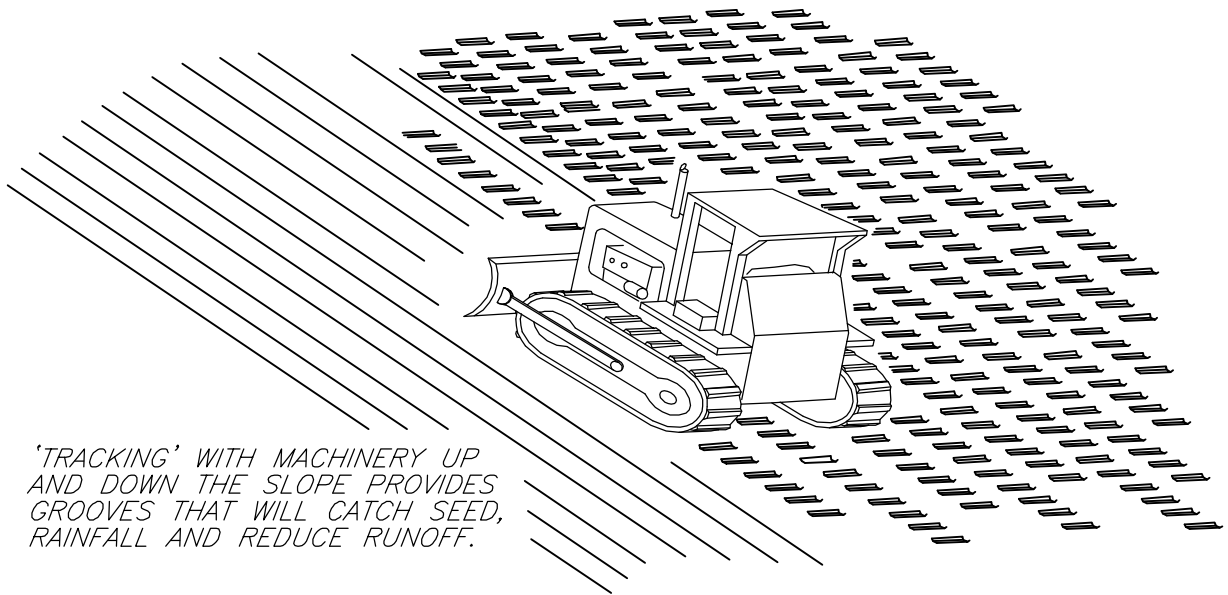

*'TRACKING' WITH MACHINERY UP AND DOWN THE SLOPE PROVIDES GROOVES THAT WILL CATCH SEED, RAINFALL AND REDUCE RUNOFF.*

**TRACKING**

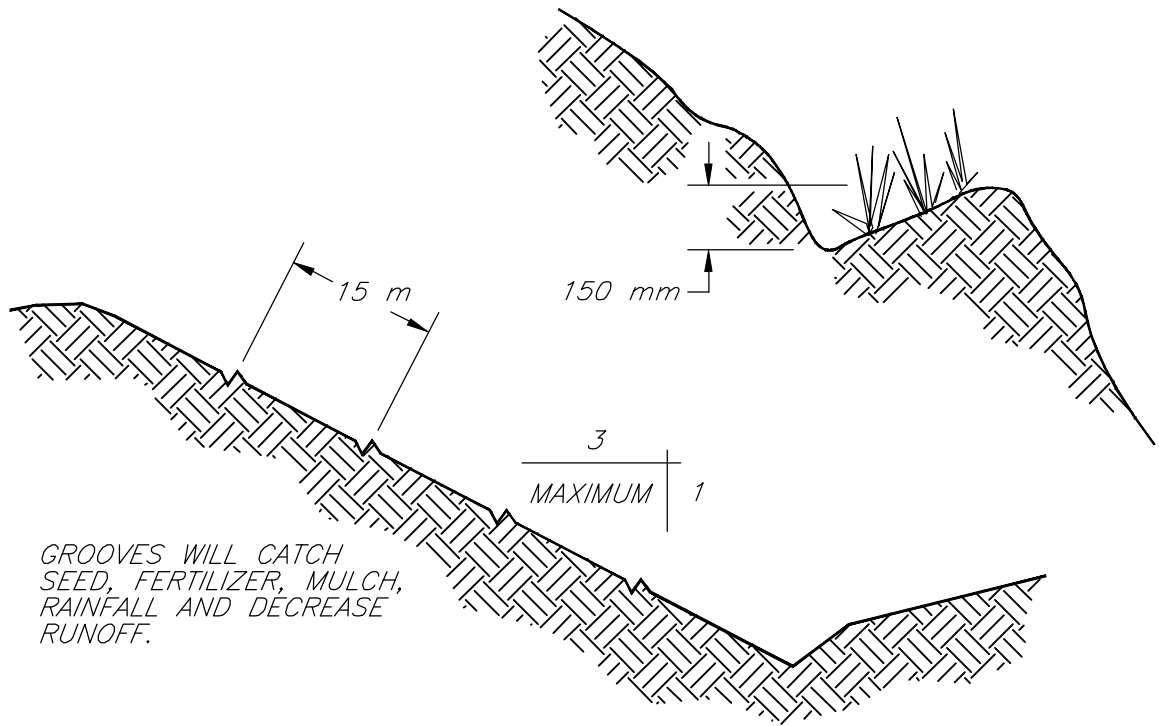

*GROOVES WILL CATCH SEED, FERTILIZER, MULCH, RAINFALL AND DECREASE RUNOFF.*

**CONTOUR FURROWS**

**SURFACE  
ROUGHENING**

From: Salix-Applied Earthcare - EROSION DRAW 3.0  
1994 JOHN McCULLAH



FILE: SRFROUGH

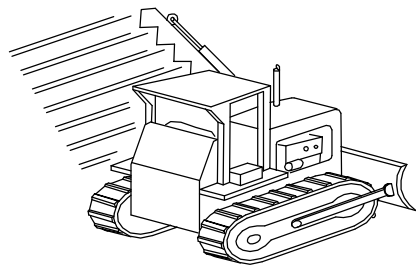
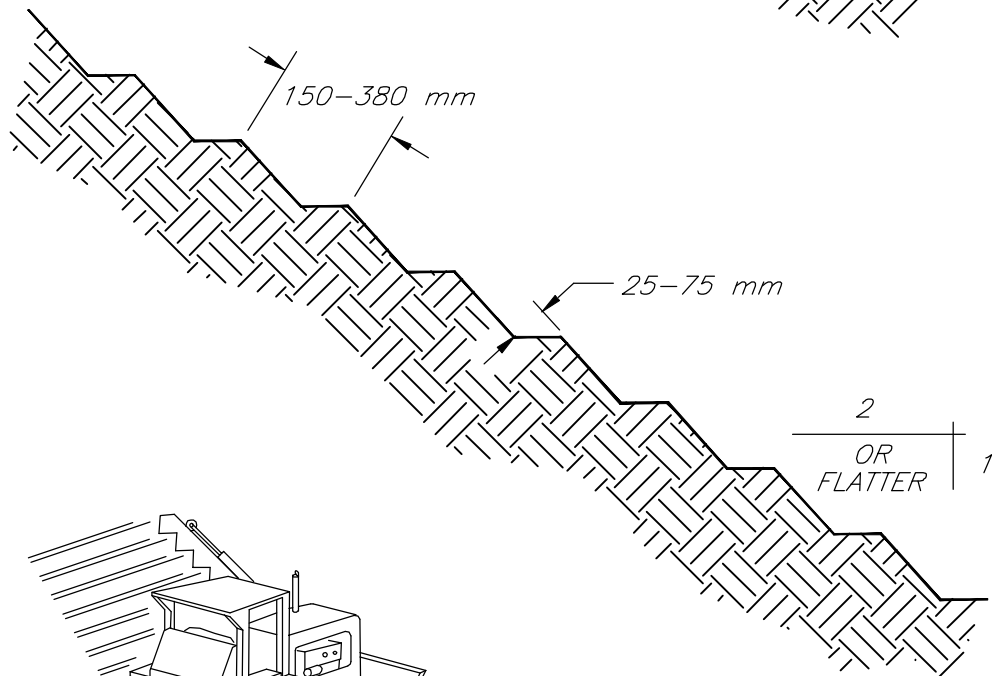
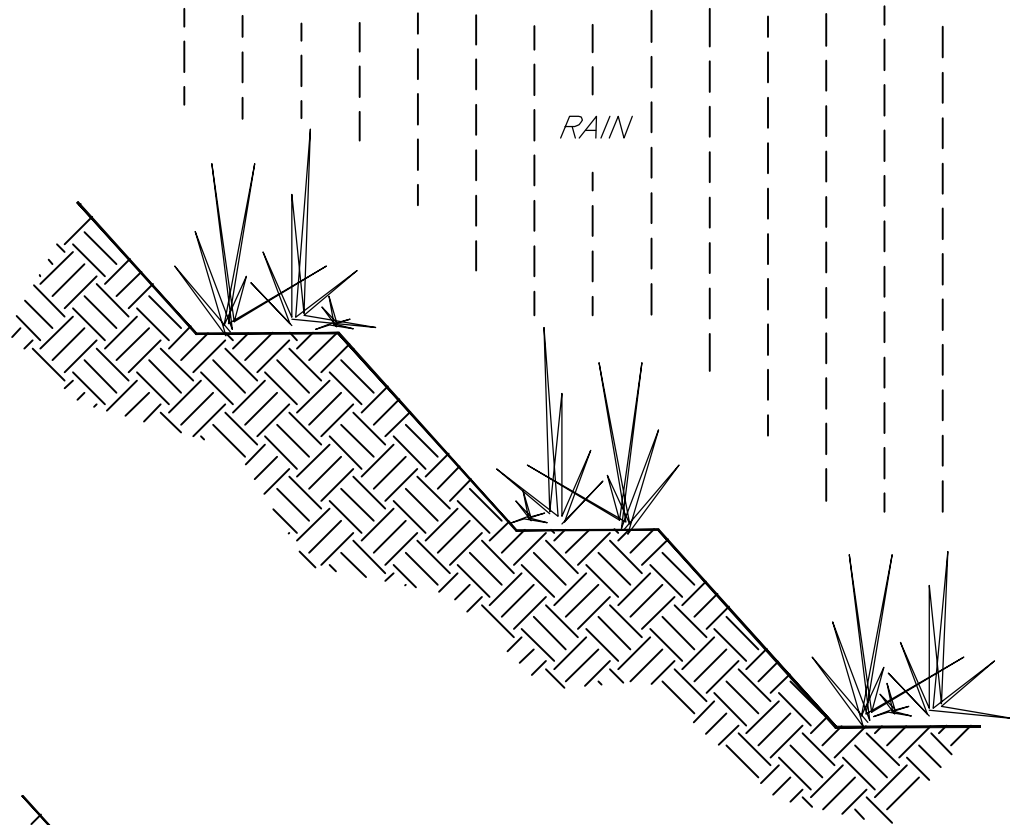

*NOT TO SCALE*

**NOTE:**

GROOVE BY CUTTING SERRATIONS ALONG THE CONTOUR. IRREGULARITIES IN THE SOIL SURFACE CATCH RAINWATER, SEED, MULCH AND FERTILIZER.

**GROOVED OR  
SERRATED SLOPE**

From: Salix-Applied Earthcare – EROSION DRAW 3.0  
1994 JOHN McCULLAH



FILE: SERSLOPE

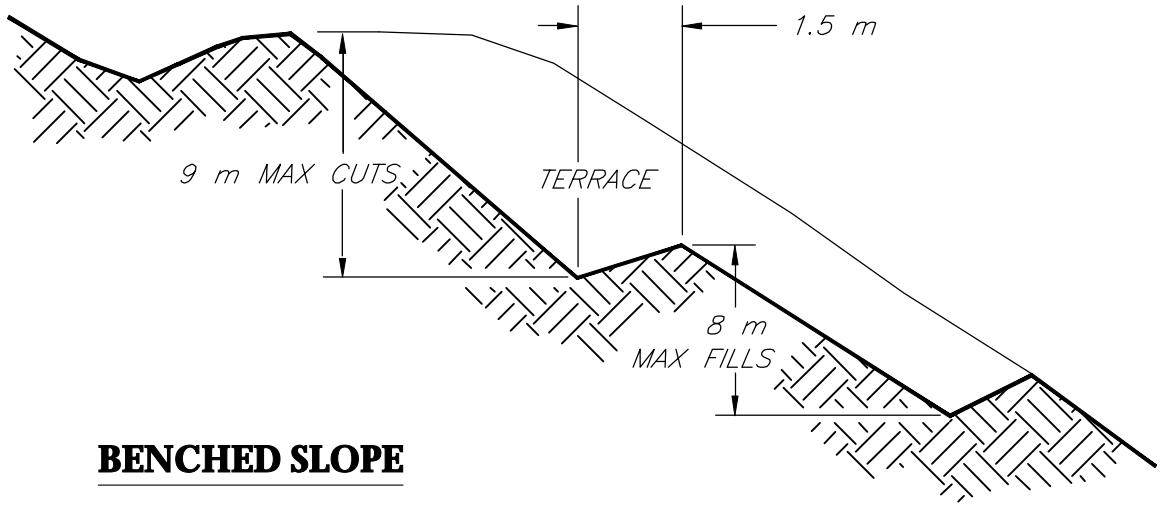

**BENCHED SLOPE**

*NOT TO SCALE*

**BENCHED SLOPE**

From: Salix—Applied Earthcare — EROSION DRAW 3.0  
1994 JOHN McCULLAH



FILE: STPSLOPE

## Rolls

- a) Coir Roll
- b) Fibre Roll

## Streambank Stabilization Techniques and Erosion Control

B.M.P. #38

### Description and Purpose

- Coir Rolls are long cylindrical tubes that are composed of interwoven coconut fibres which are bound together with durable coir netting. Coir rolls are particularly applicable for wetland, streambank, and shoreline projects. Coir rolls are most commonly available in 300mm diameters and 6m lengths. These rolls can be linked together to form longer tubes, and are often used in combination with other biotechnical techniques, such as brush layering or live siltation. Coir logs encourage siltation and wetland/floodplain creation
- Fibre rolls are installed across slope contours as a grade break to reduce erosion potential by reducing overland flow velocities
- Straw roll consists of bundled straw (or natural fibre) wrapped in photo-degradable open-weave plastic netting staked into the soil along slope contours as a grade break to reduce erosion potential
- Normally live staking can be installed to anchor the Fibre Rolls to provide deep root vegetation with potential favourable moisture retention provided by fibre roll
- Fibre Rolls also capture sediment, organic matter, and seeds carried by runoff

### Applications

- The tough, long-lasting coconut fibres make coir rolls appropriate for wetland, streambank, and shoreline applications. Coir rolls work well when immediate erosion control is needed. Brushlayers work well with coir roll applications, adding further stabilization with a live root system, while also providing excellent habitat features. The coir roll provides a base for the brushlayer cuttings to be laid upon at an appropriate angle which benefits the growth of cuttings. The cuttings provide further protection from breaking waves and high flows
- Fibre Rolls may be used on slopes stable enough to support vegetation (steep, confined, slopes and channel banks with gradients greater than 1H:1V may have low success potential)
- Fibre Rolls may be used along long slopes as a grade break to shorten slope length between line of fibre rolls at different contour elevations
- Fibre Rolls may be used as grade breaks, where slopes transition from flatter to steep gradients

### Advantages

- The coir material is natural and long lasting (5 to 7 years), and has high tensile strength

## Rolls

- a) Coir Roll
- b) Fibre Roll

## Streambank Stabilization Techniques and Erosion Control

B.M.P. #38

- The fibre rolls and mats accumulate sediment while the plants grow and the plant roots develop. Eventually the coir material biodegrades and the cohesive strength of the root systems and flexible nature of the plants become the primary stabilizing element
- The coir roll/brushlayering combination provides immediate shoreline and streambank protection, with additional benefits of riparian enhancement when the cuttings become established
- Coir Rolls address ecological concerns by encouraging vegetation and wildlife habitat, and are an alternative to stone revetments or other structural measures
- The high tensile strength coconut fibres, fibre netting and the wooden stakes used to anchor the material make up the initial structural components of the system, while plant root and top growth increase the strength and baffle effects of the structure
- Fibre Rolls can be used on slopes too steep for silt fences or straw bales sediment barriers
- In time, plastic netting will degrade due to the sunlight and straw will degrade and be incorporated into the soil
- Fibre Rolls primary purpose is erosion control, however fibre rolls do provide some sediment control

### Limitations

- This technique should be implemented during the dormancy period of the cuttings used for brushlayering and staking
- Coir Rolls are relatively expensive
- Fibre Rolls are designed for low sheet flow velocities
- Fibre Rolls are designed for short slopes with a maximum gradient of 1H:1V
- Fibre Rolls may be labour intensive to install
- Straw rolls have short life span due to natural degradation
  - Usually only functional for two seasons
- Susceptible to undermining and failure if not properly keyed into the soil
- Labour intensive maintenance may be required to ensure rolls are in continuous contact with the soil, especially when used on steep slopes or sandy soils

## Rolls

- a) Coir Roll
- b) Fibre Roll

## Streambank Stabilization Techniques and Erosion Control

B.M.P. #38

### Construction

- Determine annual water elevation
- Mark the annual water level on a stake driven into the substrate, 0.3 or 0.6 m offshore. Installing the materials and plants at the correct elevation is the most important aspect to assure success of the installation. Determine, on site, where the installation will begin and end
- Determine soil level by laying a straight cutting on the coir roll with approximately 20% of the cutting sticking out past the roll, and with the basal ends dipping down into the soil
- Begin installation at the downstream end (if using in a streambank project)
- Prepare the site for installation of coir roll and coir mats by removing any large rocks, obstructions or material that may prevent the coir from making direct and firm contact with the soil. Coir rolls must be level, installed along a horizontal contour. Place coir rolls parallel to the stream bank or shoreline. It is very important to key the ends of the coir rolls firmly into the shoreline or stream bank, so waves and flows will not scour behind the rolls and compromise the integrity of the structure
- Install the coir roll such that 50 mm of the roll extends above the annual water elevation
- Adjacent rolls shall be laced together, end-to-end, tightly and securely
- If using brushlayer cuttings prepare soil bed behind installed coir rolls for laying. It is important that the bud ends of the live cuttings angle up to some degree from the basal ends. Lay cuttings in this fashion, slightly crisscrossed for additional strength
- Next, backfill over cuttings with soil, covering the lower 80% of the branches. At this time, soil can be levelled and prepared for a soil wrap for additional height and soil stability
- If simply covering the cuttings with soil, compact slightly and grade slope to appropriate angle. Use water to wash soil in between branch layers
- If using plant materials, such as container-grown, pre-rooted plant plugs or willow stakes, they should be planted into the coir rolls and through the coir mats and netting
- To install plant plugs and willow stakes into the coir roll, use a planting iron or pilot bar into the roll and wedge it back and forth to create a hole for the plant. It is extremely important that the root system of the plant be placed below the water

## Rolls

- a) Coir Roll
- b) Fibre Roll

## Streambank Stabilization Techniques and Erosion Control

B.M.P. #38

level for certain species. All plants shall be checked to ensure that they have been firmly installed in the fibre material

- Mulch and seed exposed areas with native species
- Prepare slope face and remove large rocks or other deleterious materials
- Excavate small trenches a minimum of 0.15 m deep and 0.15 m wide across the width of the slope, perpendicular to slope direction, starting at the toe of the slope and working upwards towards crest of slope
- Space trenches a maximum of 3 to 8 m apart along the slope incline, with steeper slopes having trenches spaced closer together
- Place fibre rolls into trench ensuring continuous contact between fibre roll and soil surface
- Butt-joint adjacent fibre roll segments tightly against one another
- Use a metal bar to make pilot hole through middle of the fibre roll a minimum depth of 0.3 m into underlying soil
- Pilot holes should be spaced a maximum of 1 m apart
- Secure fibre roll to soil using wooden stake or other appropriate anchor; live stake may be used as alternate anchor
- Place soil excavated from trench on upslope side of fibre roll and compact to minimize undermining of fibre roll by runoff
- Seed the soil along the upslope and downslope sides of the fibre roll to promote vegetation growth

### Construction Considerations

- All work site disturbance should be minimized. Protect any existing plant, when possible, and avoid additional disturbance that can lead to erosion and sedimentation
- Install additional erosion and sediment control measures such as temporary diversion dikes, silt fences and continuous berms, as needed, before beginning work
- Coir rolls can be used in the stream as a sediment barrier, silt curtain, and/or coffer dam to control sediment while work is being done in the water
- Topsoil should be saved, if possible, and replaced once the subsoil has been removed or regraded. Soil shall be stored away from the water's edge and it shall be moved to its final location and stabilized as quickly as possible

## Rolls

- a) Coir Roll
- b) Fibre Roll

## Streambank Stabilization Techniques and Erosion Control

B.M.P. #38

- For typical applications at the water's edge, coir rolls are held in place with a single row of stakes, 300 mm on center. Stakes may be driven through the netting on the outer edge of the roll. It is very difficult to drive stakes through the high-density rolls, however, a stake can be driven with the help of a pilot hole through the low density coir rolls
- Lacing among the stakes is recommended for coir mats exposed to extreme conditions such as ice, waves, or flooding
- Coir rolls shall be placed along streambanks or shorelines at a height sufficient to protect the bank from flows or waves. Additional coir rolls may be placed above the lower rolls, in a tile-like fashion, to protect the upper shore or stream bank
- Use live stakes in place of wooden stakes
- If the slope soil is loose and uncompacted, excavate trench to a minimum depth of 2/3 of the diameter of the fibre roll
- For steep slopes, additional anchors placed on the downslope side of the fibre roll may be required

### Inspection and Maintenance

- Inspection frequency should be in accordance with the PESC and TESC Plans
- Check plants to ensure that they have been firmly installed in the fibre material
- Water plants, if necessary, during the establishment phase
- Check all materials periodically or after storms to ensure they remain properly secured. Make necessary repairs promptly
- All temporary and permanent erosion control practices shall be maintained and repaired as needed to ensure continued performance of their intended use
- Areas damaged by washout or rutting should be repaired immediately
- Additional stormwater control measures should be considered for rilling areas damaged by runoff

Place coir rolls parallel to the streambank along a horizontal contour.

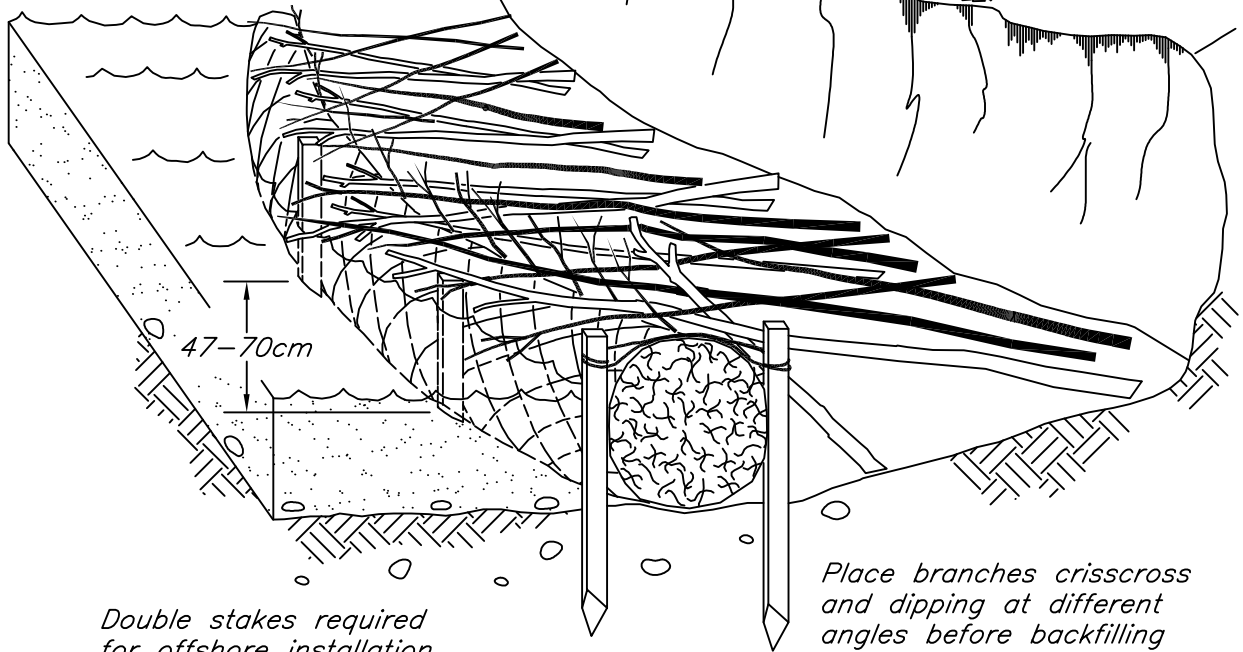

Double stakes required for offshore installation.

Place coir roll such that the roll extends 50mm above mean water elevation.

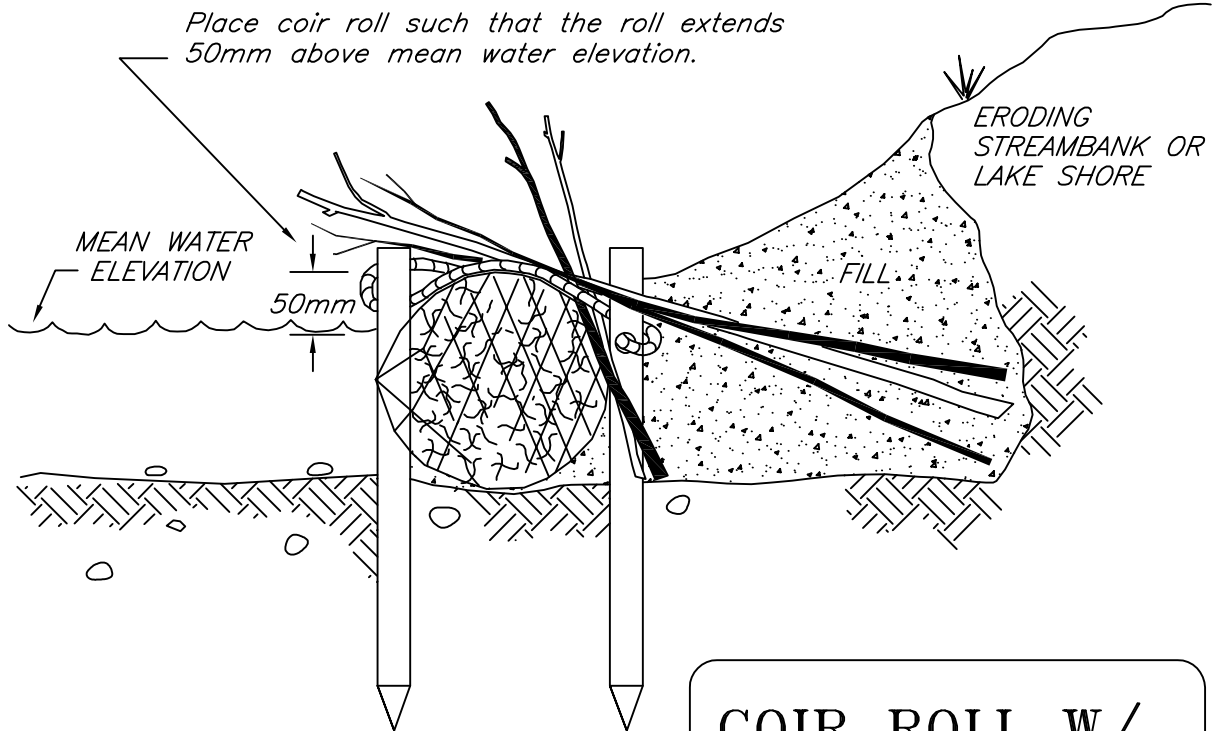

COIR ROLL W/  
BRUSHLAYERING

© 2000 JOHN McCULLAH



FILE: COIRBRLY

PLACE COIR ROLLS PARALLEL TO THE STREAMBANK ALONG A HORIZONTAL CONTOUR

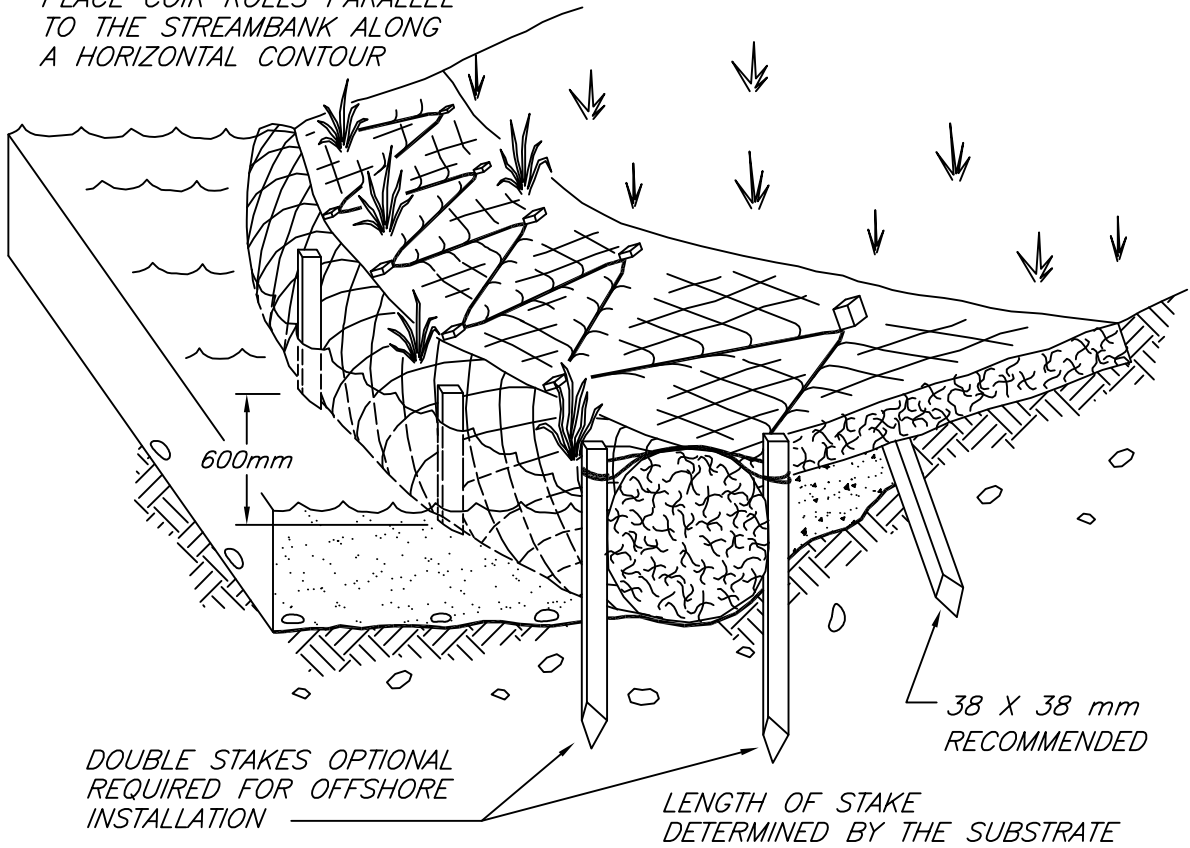

PLACE COIR ROLL SUCH THAT THE ROLL EXTENDS 50 mm ABOVE MEAN WATER ELEVATION

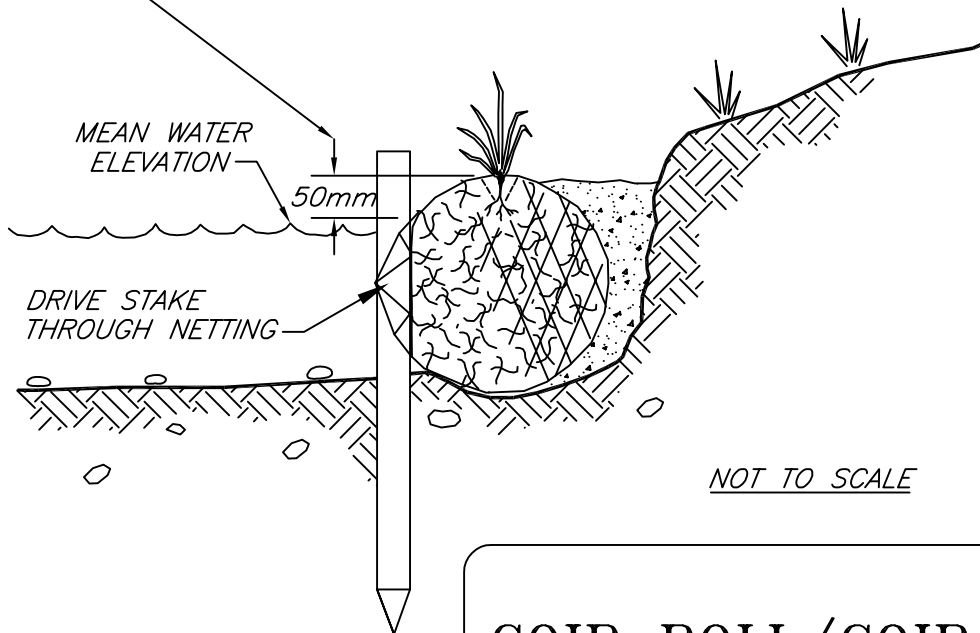

## COIR ROLL/COIR MATS

© 1996 JOHN McCULLAH

FILE: COIRRM

STRAW ROLLS MUST BE PLACED ALONG SLOPE CONTOURS

ADJACENT ROLLS SHALL TIGHTLY ABUT

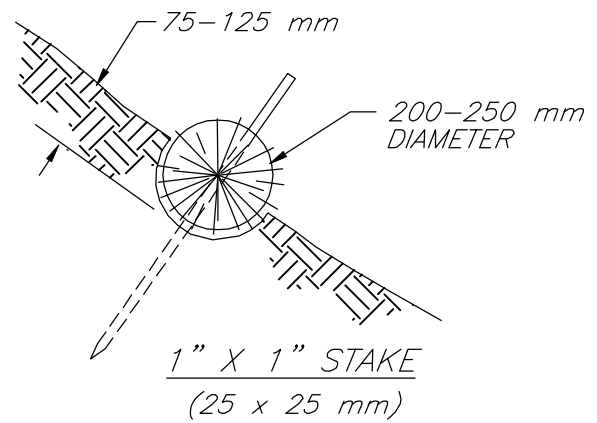
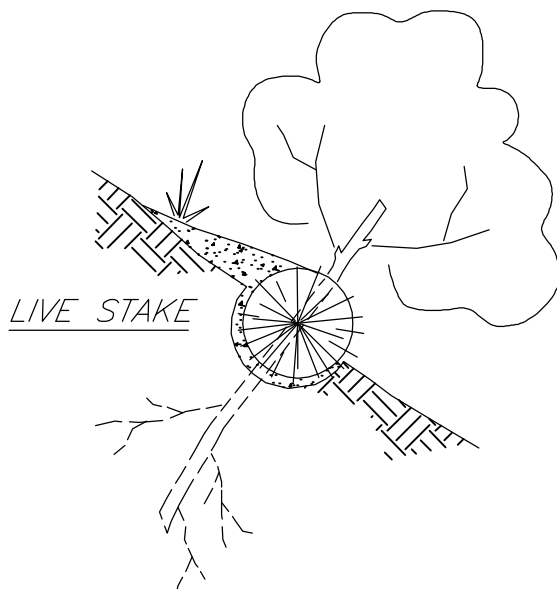
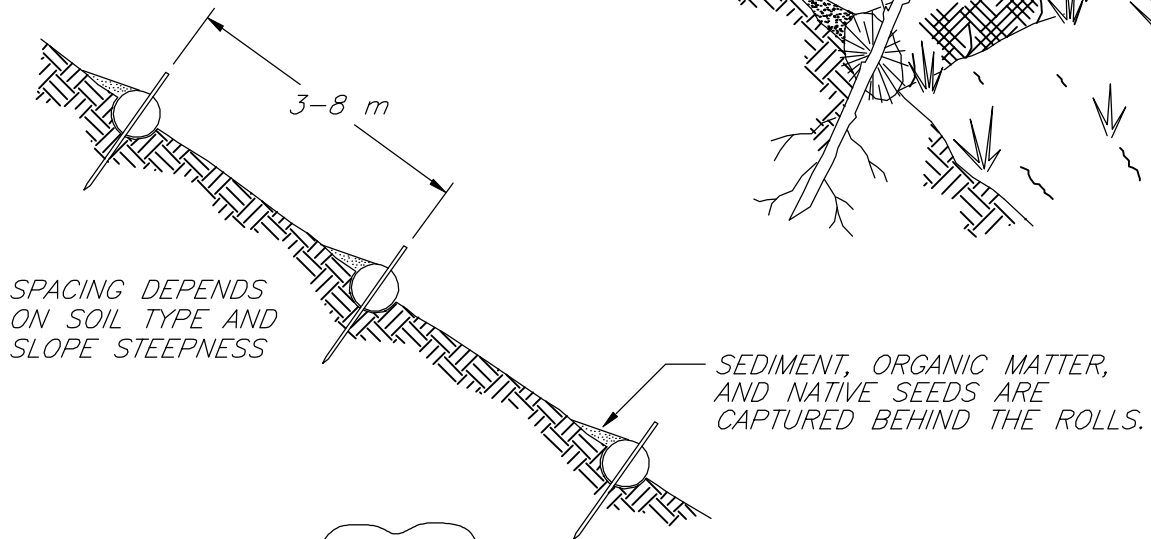

**NOTE:**

1. STRAW ROLL INSTALLATION REQUIRES THE PLACEMENT AND SECURE STAKING OF THE ROLL IN A TRENCH, 75-125 mm DEEP, DUG ON CONTOUR. RUNOFF MUST NOT BE ALLOWED TO RUN UNDER OR AROUND ROLL.
2. THIS FIGURE IS PROVIDED FOR GUIDANCE ONLY AND DOES NOT CONSTITUTE A DESIGN. A SITE SPECIFIC DESIGN IS REQUIRED FROM DESIGNER/ENGINEER.

NOT TO SCALE

# STRAW ROLLS

From: Salix-Applied Earthcare - EROSION DRAW 3.0  
1996 JOHN McCULLAH



FILE: STRWROLL

**LYNN LAKE GOLD PROJECT:  
EROSION AND SEDIMENT CONTROL PLAN**

Appendix B Maps  
January 30, 2025

## **Appendix B Maps**

**Sensitive Sites**

- Area Watercourses
- Area Waterbodies
- Ground-truthed Swamps from field surveys

**Project Infrastructure**

- Communication Tower
- Collection Pond Discharge Pipeline Corridor
- Contact Water Ditch
- Discharge Pipeline Corridor
- Diversion Ditch
- Interceptor Well Discharge / Fresh water corridor
- Interceptor Well Discharge Pipeline Corridor
- Collection Pond/Sumps
- Facility Area
- Gen Set Area
- MRSA
- Open Pit
- Ore Storage
- Overburden Storage
- Topsoil Storage Area
- Stockpile Borrow Source
- Project Development Area (PDA)

**Landbase**

- Existing Access Road
- Waterbody
- Watercourse

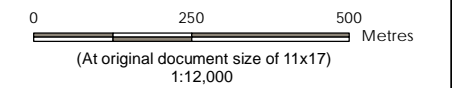

- Notes**
1. Coordinate System: NAD 1983 UTM Zone 14N
  2. Base Data Sources: Government of Manitoba and Government of Canada.
  3. NOA Project Infrastructure features provided by Worley via Alamos.

**Project Location**  
Lynn Lake, Manitoba  
Prepared by ACampigotto on 2023-11-16  
Technical Review by GBarber on 2023-11-16

**Client/Project**  
ALAMOS GOLD INC.  
Lynn Lake Gold Project  
111473054

**Map No.**  
**1**  
**Title**

**Sensitive Sites - Gordon site**

G:\\_GIS\_Projects\Folder\111473054\_LGIP\_EA\RA\Sensitive\_Sites\Map1\_SensitiveSites\_Gordon\_NOA\_20231116.mxd Revised: 2023-11-16 By: ACampigotto

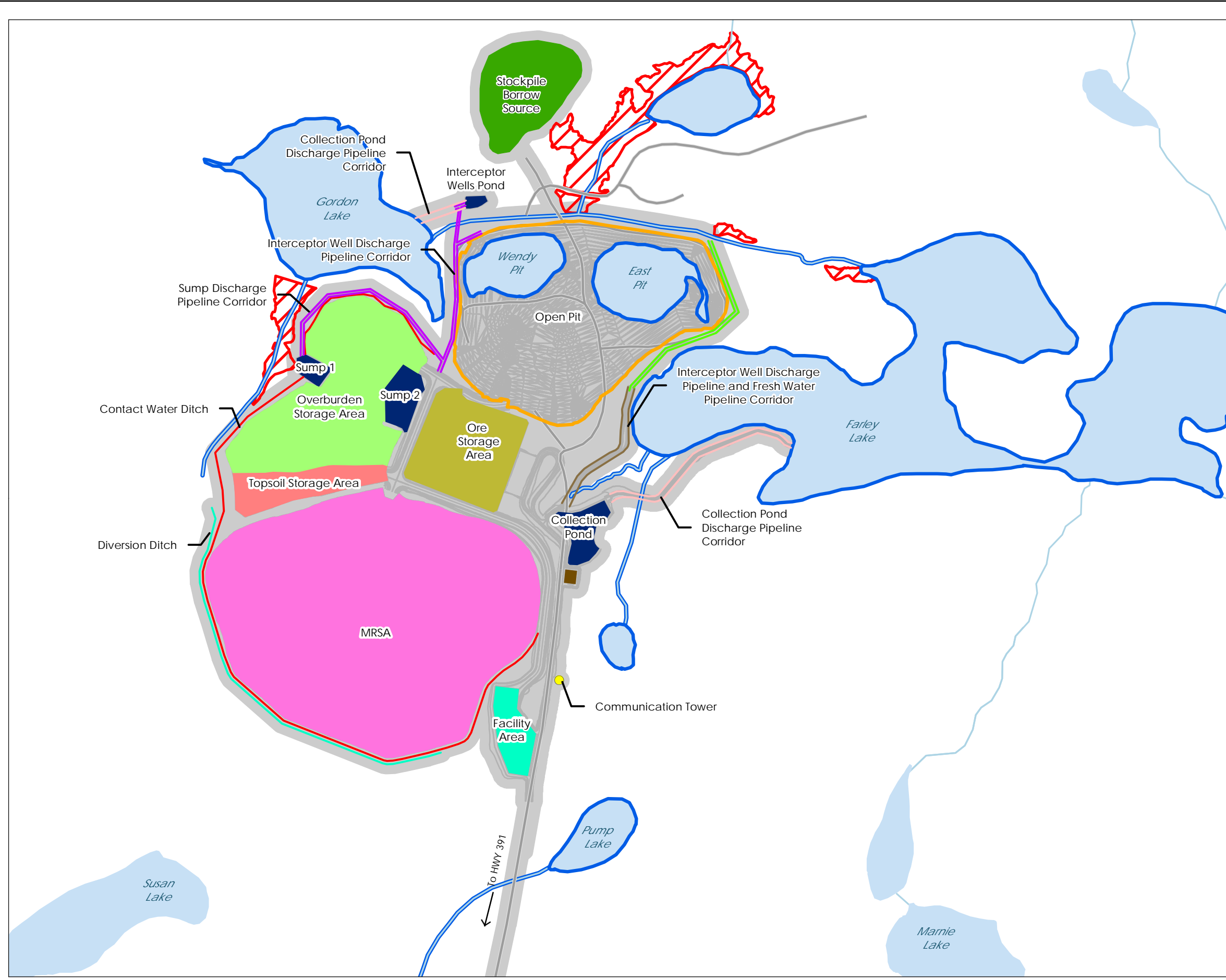

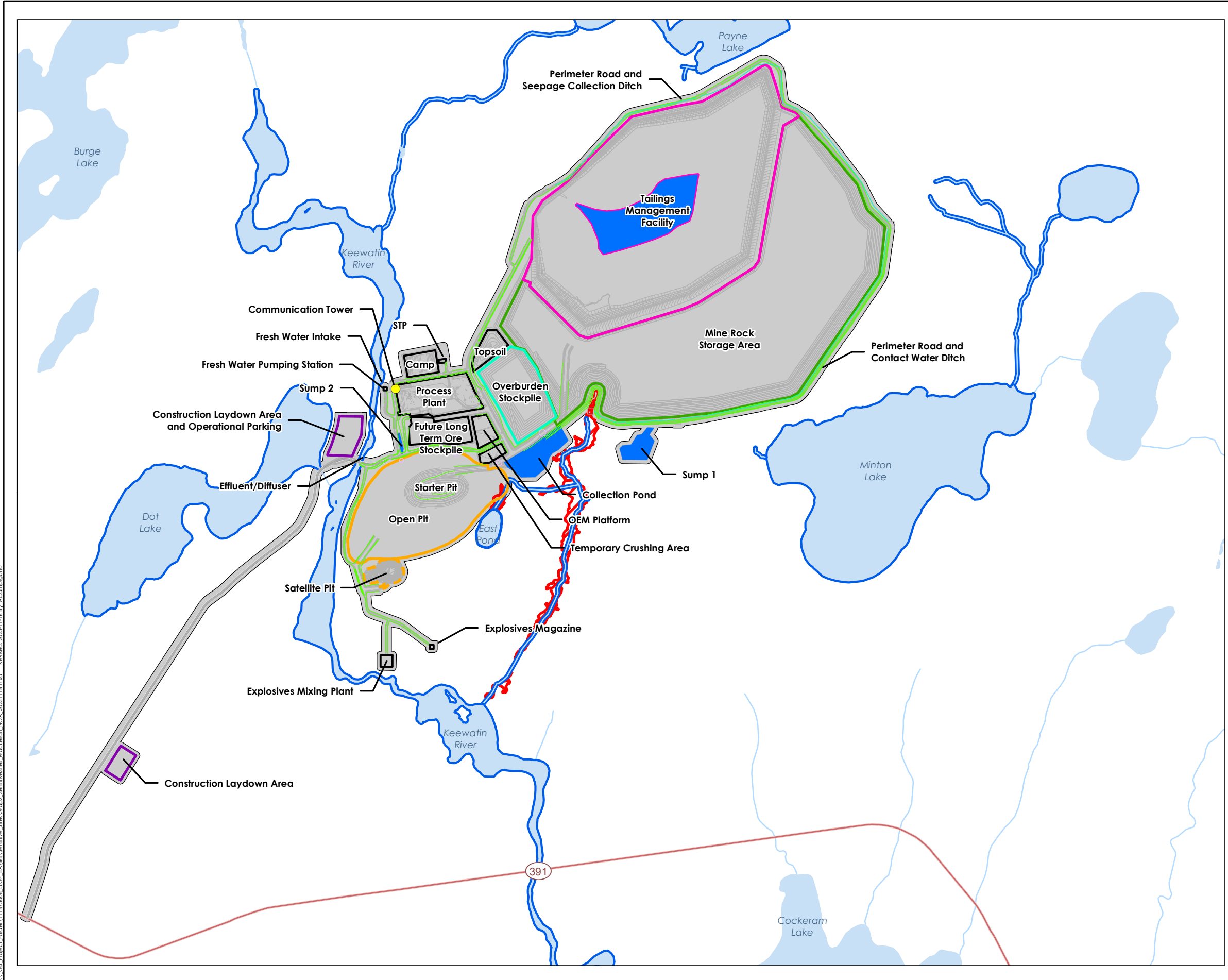

**Sensitive Sites**

- Area Watercourses
- Area Waterbodies
- Ground-truthed Swamps from field surveys

**Project Infrastructure**

- Communication Tower
- Culvert
- Ditching
- Corridor / Access Road
- MRSA
- Overburden Stockpile
- TMF
- Open Pit
- Satellite Pit
- Collection Pond/Sumps
- Other Infrastructure
- Construction Laydown Area
- Project Development Area (PDA)

**Landbase**

- Highway
- Existing Access Road
- Watercourse
- Waterbody

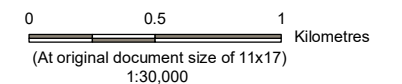

- Notes**
1. Coordinate System: NAD 1983 UTM Zone 14N
  2. Base Data Sources: Government of Manitoba and Government of Canada.
  3. Project Infrastructure features provided by QPit and Ausenco.

**Project Location**  
Lynn Lake, Manitoba

Prepared by ACampigotto on 2023-11-16  
Technical Review by GBarber on 2023-11-16

**Client/Project**  
ALAMOS GOLD INC.  
Lynn Lake Gold Project

111473054

**Map No.**  
**2**

**Title**  
**Sensitive Sites - MacLellan site**

G:\\_GIS\_Projects\Folder\111473054\_LGPF\_EA\RA\Sensitive\_Sites\Map2\_SensitiveSites\_MacLellan\_NGA\_20231116.mxd - Revised: 2023-11-16 by: ACampigotto

**Project Development Area**

Project Development Area (PDA)

**Erosion Risk**

Wind Erosion Risk

High

Low

Water Erosion Risk

Medium

Low

Very Low

**Landbase**

Ground Surface Elevation Contours (masl)

Existing Access Road

Existing Diversion Channel

Surface Water Flow Direction

Watercourse

Waterbody

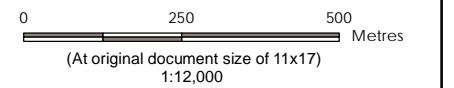

- Notes**
1. Coordinate System: NAD 1983 UTM Zone 14N
  2. Base Data Sources: Government of Manitoba and Government of Canada.
  3. NOA Project Infrastructure features provided by Worley via Alamos.

**Project Location** Lynn Lake, Manitoba  
 Prepared by ACampigotto on 2024-12-18  
 Technical Review by KMathers on 2024-12-18

**Client/Project** ALAMOS GOLD INC.  
 Lynn Lake Gold Project  
 111473076

**Map No.**  
**3**

**Title**  
**Erosion Risk -Gordon site**

G:\\_GIS\_Projects\Folder111473076\_EA\admin\data\_sou\STANTEC\20241017\_sols\_data\_for\_tomas\Gordon\_Erosion\_Plan\_with\_z\_contours\_NOA\_PDA\_20241218.mxd Revised: 2024-12-18 By: ACampigotto

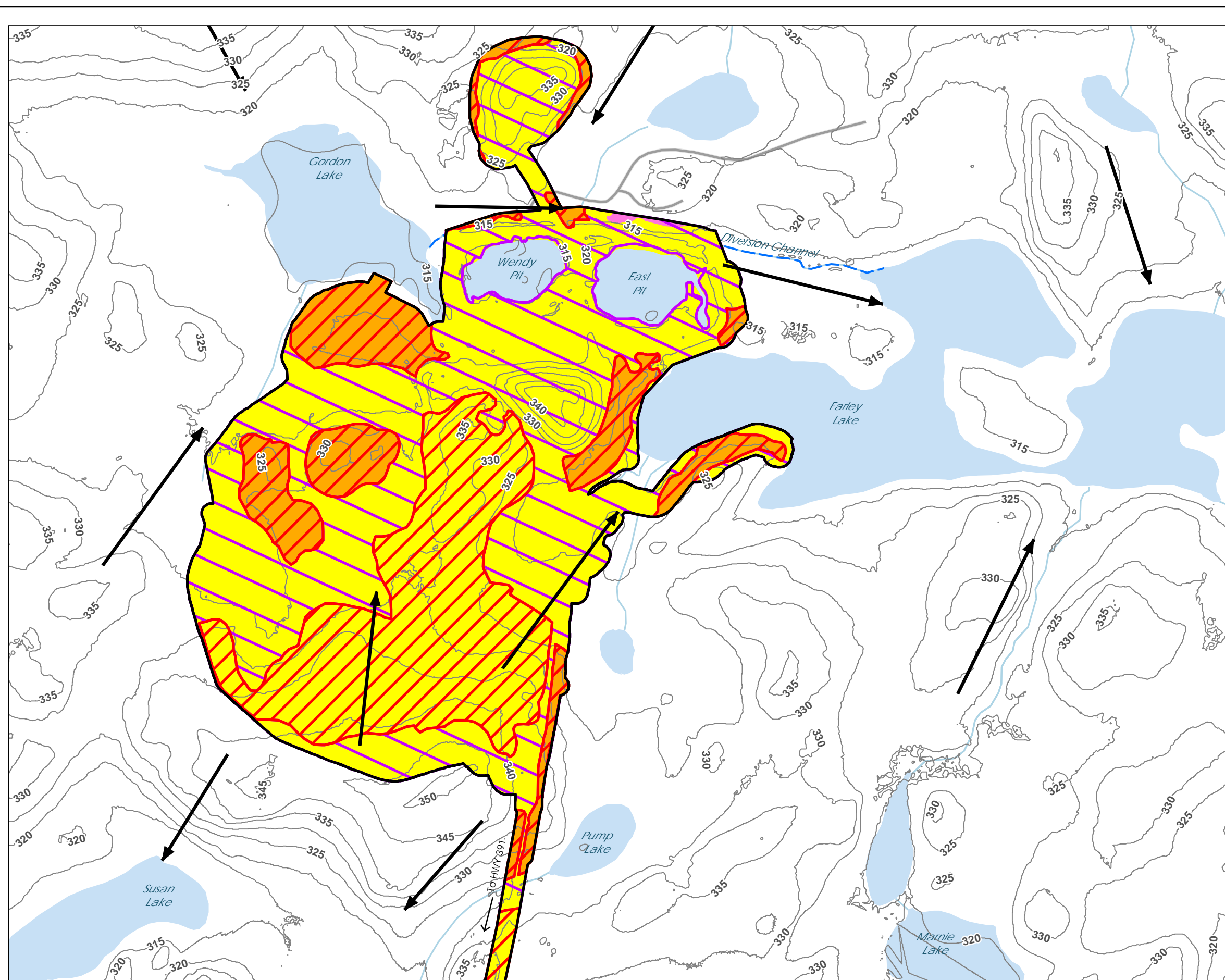

G:\\_CS\_Project\_Folder\11473076\_01\STANTEC\20241017\_sols\_data\_for\_tomas\MapLellan\_Erosion\_Plan\_with\_z\_contours\_NDA\_FDA\_20241218.mxd Revised: 2024-12-18 By: ACampigotto

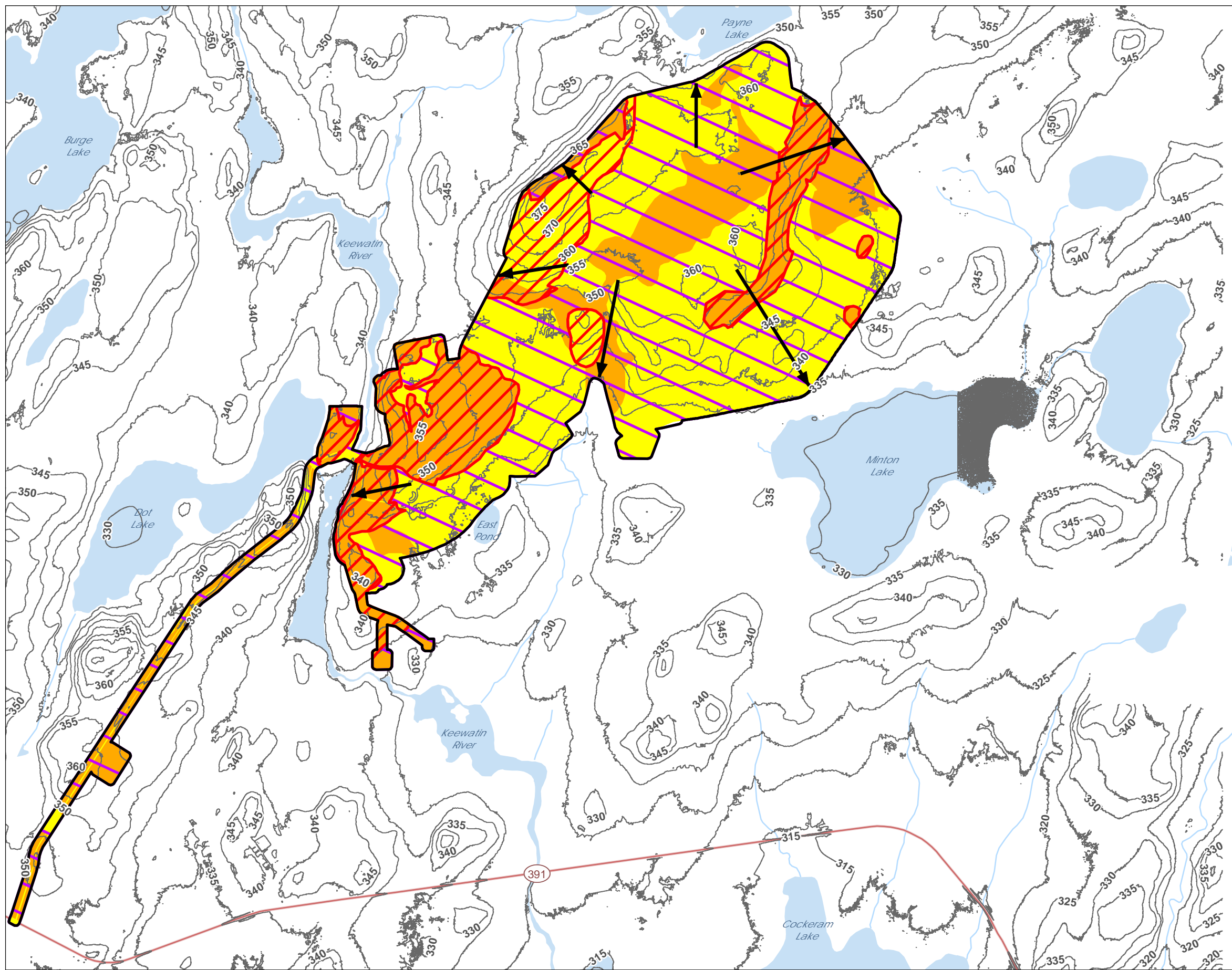

**Project Development Area**

Project Development Area (PDA)

**Erosion Risk**

Wind Erosion Risk

High

Low

Water Erosion Risk

Low

Very Low

**Landbase**

Ground Surface Elevation Contours (masl)

Highway

Existing Access Road

Surface Water Flow Direction

Watercourse

Waterbody

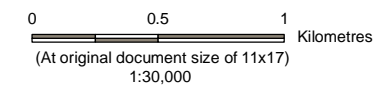

- Notes**
1. Coordinate System: NAD 1983 UTM Zone 14N
  2. Base Data Sources: Government of Manitoba and Government of Canada.
  3. Project Infrastructure features provided by QPit and Ausenco.

**Project Location** Lynn Lake, Manitoba  
 Prepared by ACampigotto on 2024-12-18  
 Technical Review by KMathers on 2024-12-18

**Client/Project** ALAMOS GOLD INC.  
 Lynn Lake Gold Project  
 111473076

Map No.

4

Title

**Erosion Risk -MacLellan site**